

Installation Guide

For DC Electric Windlass Models

MIDI 202



SLEIPNER AS

P.O. Box 519

N-1612 Fredrikstad

Norway

www.sleipnergroun.com

DOCUMENT ID: 6592

REVISION: I3

DATE: 2021

LANGUAGE: EN

MI

Contents

Installation Manual

Responsibility of the Installer.....	3
Windlass Measurements	4
Windlass Specifications	5
Technical Specifications	5
Installation Preparation	6
Windlass Mounting Installation	7
Insert Rope Into The Windlass Line Wheel	8
Rope Around The Line Wheel	9
Rope Clearance	10
Rope Stop Rings for Auto Stop.....	10
Rope Stop Ring Installation	11
Visual Wiring Diagram	12
Windlass Electrical Installation	13 - 14
Windlass Circuit Breaker	15
Pre-delivery Checklist	16
Service and Support.....	17
Product Spare Parts and Additional Resources.....	17
Warranty Statement.....	17

Products

SM158441 | 36-12108 - Side-Power Midi 202



Sleipner Motor AS
P.O. Box 519, Arne Svendsensgt. 6-8
N-1612 Fredrikstad, Norway

MC_0020

Failure to follow the considerations and precautions can cause serious injury, damage and will render all warranties given by Sleipner Motor as VOID.

MC_0411

Responsibility of the Installer

MC_0038

The installer must read this document to ensure necessary familiarity with the product before installation.

Instructions in this document cannot be guaranteed to comply with all international and national regulations. It is the responsibility of the installer to follow all applicable international and national regulations when installing Sleipner products.

The recommendations given in this document are guidelines ONLY, and Sleipner strongly recommends that advice is obtained from a person familiar with the particular vessel and applicable regulations.

This document contains general installation instructions intended to support experienced installers. If you are not skilled in this type of work, please contact professional installers for assistance.

If required by local regulation, electrical work must be done by a licensed professional.

Appropriate health and safety procedures must be followed during installation.

Faulty installation of Sleipner products will render all warranties given by Sleipner Motor AS.

Responsibility of the User Operating Windlass

MC_0307

Never use a windlass close to somebody in the water, an unexpected drop of the anchor can cause serious injuries.

It is the owner/ captain/ other responsible parties full responsibility to assess the risk of any unexpected incidents on the vessel.

- Keep your distance to the windlass, the rope, anchor and anchor brackets during operation
- Keep the rope/chain(*_{maxi}) under observation during anchor handling.
- Ensure anyone using the windlass knows how to operate it.
- Be aware when the anchor are raised as it can bring unwanted debris up from the bottom, potentially damaging your boat. **(NB: If the windlass is straining as the anchor is raised, stop for a few seconds and let the boat pic up momentum before continuing the raise.)**
- If the anchor is stuck, release some rope/chain and attach it to a cleat before using the boat to pull the anchor free. The windlass is not designed for loads beyond the specified pull capabilities.
- The anchor MUST ALWAYS be secured to the boat while under way. Use the security line or other means to prevent unintentional anchor drop.
- Turn off the power to the windlass when not in use.
- Children must not operate the windlass.
- Careless use can cause damage or injury!
- Ensure to have good battery capacity, and keep the engine running windlass operation.
- Sleipner Motor AS is not responsible for damage or injury caused by the use of our windlass systems.
- While dropping anchor, do not push the "UP" button until the anchor is resting at the seabed.
- Always turn the control device off when the thruster is not in use.

MIDI Considerations and Precautions

MC_0318

Sleipner Engbo MIDI is designed for boats up to approximately 25 feet. These windlasses are true free-fall windlasses and are developed with a new electrical control unit. This new unit is ready for connecting Side-Power remote control and switch panel.

Ensure there is sufficient weight from the anchor when the windlass is released. The pulling force must overcome any friction/ weight of the rope, chain and pulley system.

(NB: Over time rope becomes less flexible to bend over sharp turns or bends due to salt/ sand sediments when it dries.)

Measurement code	Measurement description	*MIDI	
		mm	inch
(a)	Motor diameter	85	3.3
H	Total Height	330	13
W	Total width	150	5.9
L	Total length	180	7.1
(b)	Motor bracket attachment measurements	29	1.14
(c)	Motor bracket attachment diameter	14	0.55
(d)	Motor bracket attachment measurements	25	0.98
(e)	Motor bracket attachment measurements	70	2.76
(f)	Motor bracket attachment measurements	30	1.18
(g)	Motor bracket attachment measurements	13	0.51
(h)	Motor bracket attachment measurements	32.5	12.8
(i)	Motor bracket attachment diameter	14	0.55
(j)	Motor bracket attachment diameter	11	0.43
(k)	Motor bracket attachment measurements	42.5	16.73
(l)	Motor bracket attachment measurements	43.5	17.13

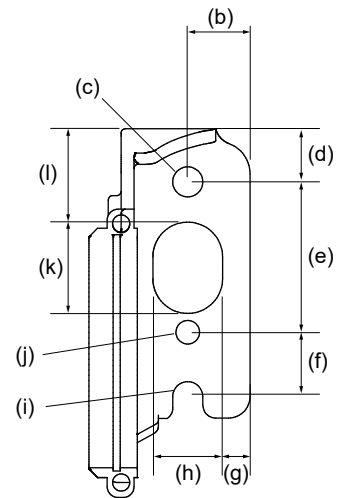
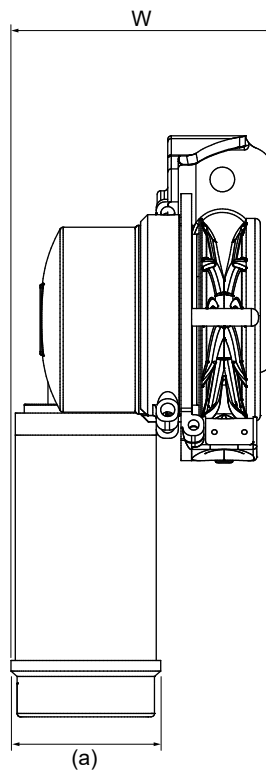
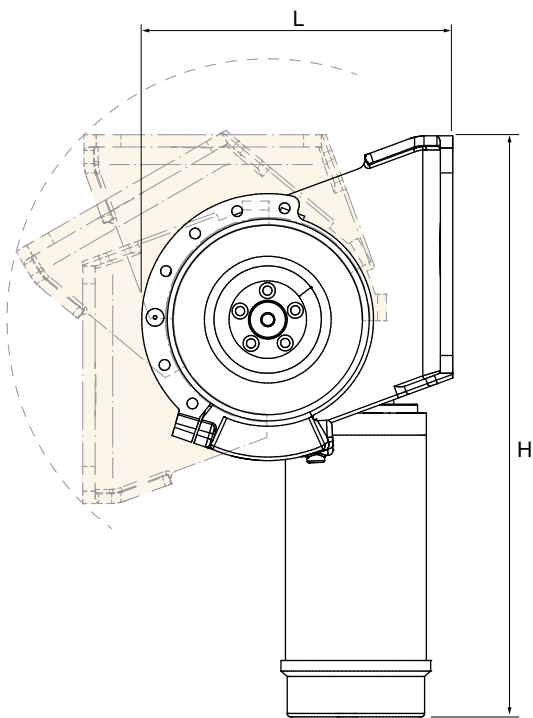

Description	* MIDI
Available DC System (v)	12v
No-Load current (v)	<0.1A with 12v
Power Consumptions	10-200A aprox 40A with 30kg load
Typical Boat Size (m * ft)	< 7m * >23ft
Pulling power (Electronically governed)	Up to 200kg
Pulling speed	15-30m/min aprox 20m/min with 30kg load
Weight (kg * lbs)	9.8kg * 21.6lbs
Minimum Battery Capacity	12v/ 75Ah

Technical Specifications

- Motor:** Custom made PMDCmotor.
- Rope:** Braided lead rope diameter 12 mm, 30/50 m
 Weight: 7.2 kg/12 kg
 Breaking load: 1600 daN
- Auto Stop:** Yes
- Anchor/ weight:** 7.5 - 16kg Bruce, plate or Side-Power
 (Recommended)
- Additional Equipment:**
- Anchor (Multiple types)
 - Anchor bracket (Multiple types)
 - Mounting brackets
 - Battery cable
 - Lead rope or chain
 - Fuse w/holder
 - Hull conduit for rope or chain
 - Wireless remote control
 - Switch panel
 - Cables
 - Control box unit

IMPORTANT

- **Ensure to have all necessary tools ready**
- **Unpack and organize all components**
- **Prepare and control the areas where all the different parts can be mounted.**
- **Follow the mounting instructions**
- **When winching the rope for the first time after mounting, make sure the rope is tight, so the rope is pulled in correctly.**

Placing the parts

You must plan the placement of the following parts:

- Winch/motor
- Switch panel
- Brackets for anchor and windlass
- Cables
- Control-box
- Rope guides
- Main switch/ miniature circuit breaker

General

The windlass should be positioned as high as possible to allow maximum space for the rope that will be stored below the windlass. The height from the bottom of the wall where the rope is stored to the bottom edge of the line wheel should be at least 50 cm, and the area should be at least 40 x 40 cm to allow room for 50 m x 12 mm anchor rope. This will prevent the rope from bunching under the windlass and assure sufficient friction between the gear leg and the rope.

(NB: Remember to attach the end of the rope somewhere inside the boat.)

Anchor bracket

Fit the windlass so the rope is wound up in line with the anchor bracket (see pictures) – numerous different models are available. The anchor bracket is working as a guide for the rope when the anchor is on the seabed and as a “seating point” for the anchor once it has been raised.

Use of anchor bracket

The bracket for the rope must be installed with the rollers outside the platform.

Standard platform roller or hinged platform roller

If the windlass is fitted low in relation to the bathing platform, so the angle between the bathing platform and the rope is too small ,and if you are using a Bruce anchor, use an Side-Power Engbo hinged platform roller.

Hull conduit / Line guide

It will often be necessary to install a hull conduit with a roller that guides the rope with low friction through the hull.

Rope

Side-Power Engbo supplies original woven anchor rope with a lead core . It is supplied in various lengths and dimensions.

Safety line

Once the anchor is seated in the anchor bracket, it must be secured with the safety line supplied.

IMPORTANT

ALWAYS attach a safety line to the anchor while underway.

Anchor bracket

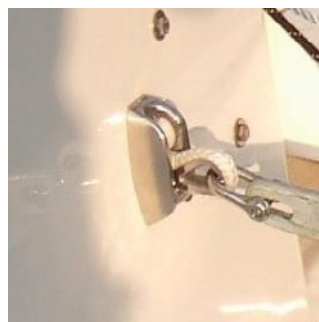

Rope



Safety line



! Please refer to the graphic for special considerations relating to your model !

Mounting

- The mounting bracket for MIDI 202 allows for infinitely variable rotation in relation to the windlass gear leg/motor.
 - The bracket for the rope guide and stop sensor can also be rotated independently of the gear leg/ motor and mounting bracket.
 - This allows for installing the windlass on surfaces with different angles in relation to the stern. It can be fitted on the inside of the stern, hanging below the deck or aft of cross bulkheads inside the boat.
1. Position the windlass mounting bracket by loosening the two screws fastening the bracket to the gear housing, rotate the windlass to the correct position and tighten the screws. **(NB: Max. tightening torque 17 Nm.)**
 2. Adjust the windlass rope guide and stop sensor in a corresponding manner by loosening the screw fastening it to the gear leg. Rotate the bracket so the rope is guided down and away from bulkheads and components that prevent the rope from coiling correctly below the windlass. **(NB: Max. tightening torque 17 Nm.)**

(NB: It is important that the rope is wound sufficiently around the line wheel to ensure a good grip on the rope. See separate section.)

(NB: The "rope guide" must be located in centre of the line wheel. Also check this after having tightened the fixing screw.)

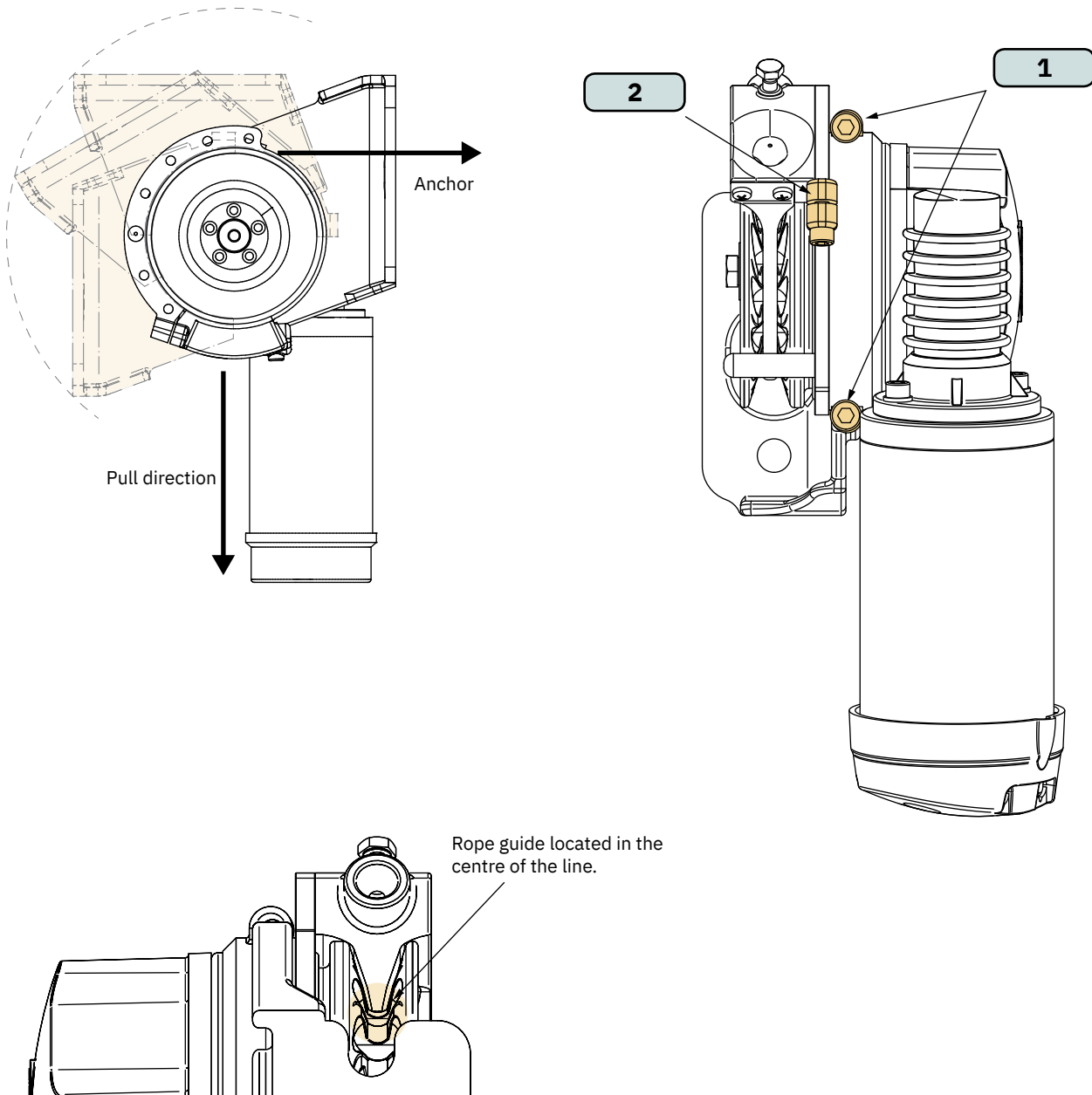

! Please refer to the graphic for special considerations relating to your model !

1. Insert the rope into the gypsy wheel between the wheel and the rope guide. It may be easier if you bend the tip of the rope guide tab carefully.
2. Route the rope via the gypsy wheel and out through the hole in the rope deflector.
3. When the windlass is connected, the rope can be pulled by pressing down on the up button on the touch panel or remote control.
4. When the tip of the rope has been pulled through the rope deflector, the rest of the rope can be pulled through using the windlass. Ensure the windlass gypsy reels as intended.

IMPORTANT

**When pulling in the rope for the first time, you must keep the rope tight, so the rope run correctly.
Be careful to avoid injuring fingers.**

Secure the end of the rope to an appropriate point after threading it through the windlass.

1

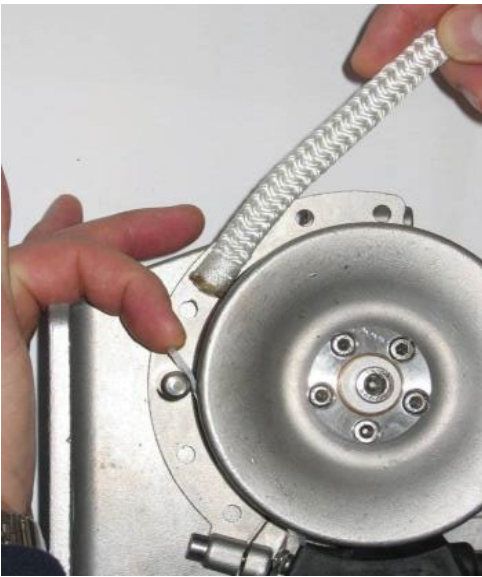

2



3

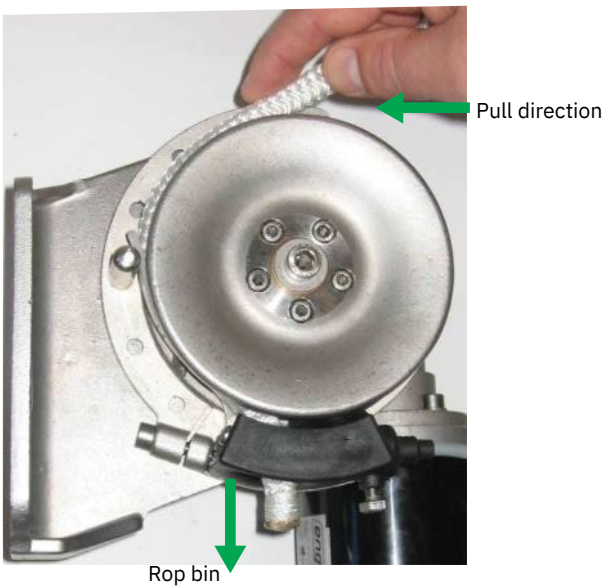

4



MG_0347

Rope Around The Line Wheel

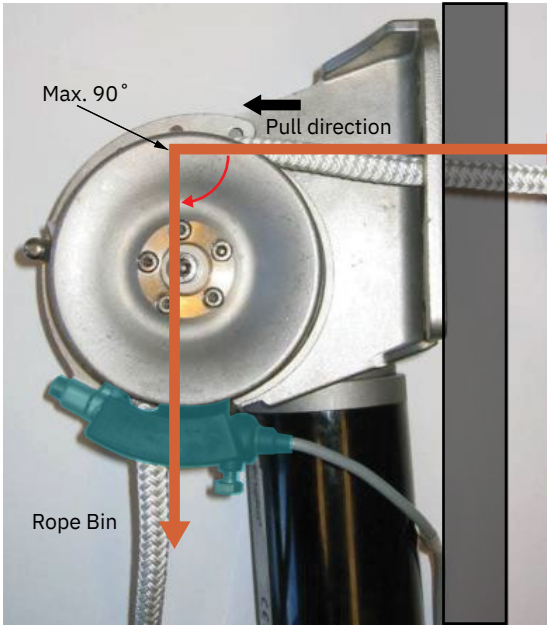

Windlass on a vertical cross bulkhead, on the inside of the stern.

Ensure the length of rope that is in contact with the gypsy wheel is sufficient to ensure good engagement/ friction with the rope.

The mounting bracket for MIDI 202 allows for infinitely variable rotation with the windlass gear leg/ motor.

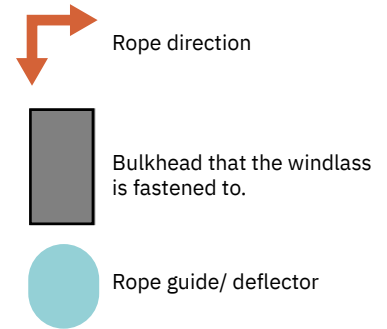

IMPORTANT
Regardless of how the windlass is fastened to the boat, the angle between where the rope enters and leaves the gypsy wheel must be maximum 90 degrees.

Ensure there is sufficient room to stow the rope below and next to the windlass.

When pulling in the rope for the first time, you must keep the rope tight, so the rope runs correctly.

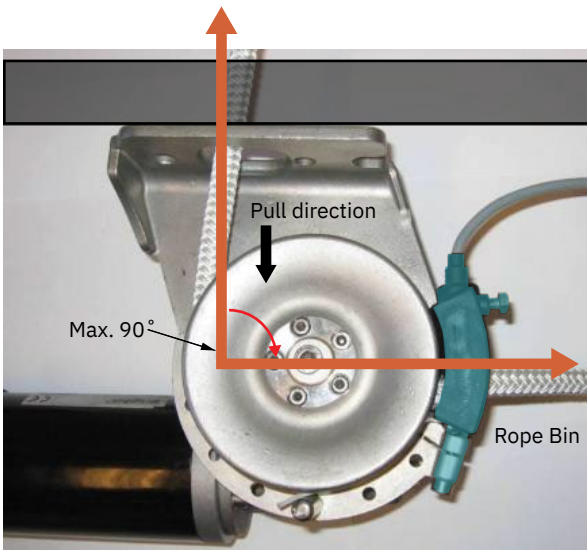

Windlass fastened below deck. The windlass mounting bracket has been rotated 90 degrees counter-clockwise .

The rope comes from above and goes down into the line wheel. In this case, the rope guide must be adjusted to ensure the rope is pushed out horizontally from the windlass.

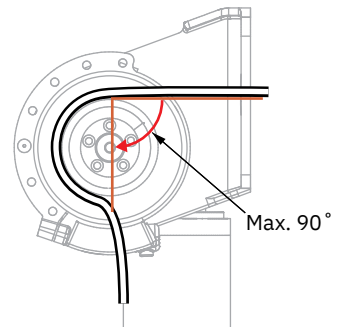

IMPORTANT
Ensure the rope travels around the gypsy to allow the teeth to catch the rope.

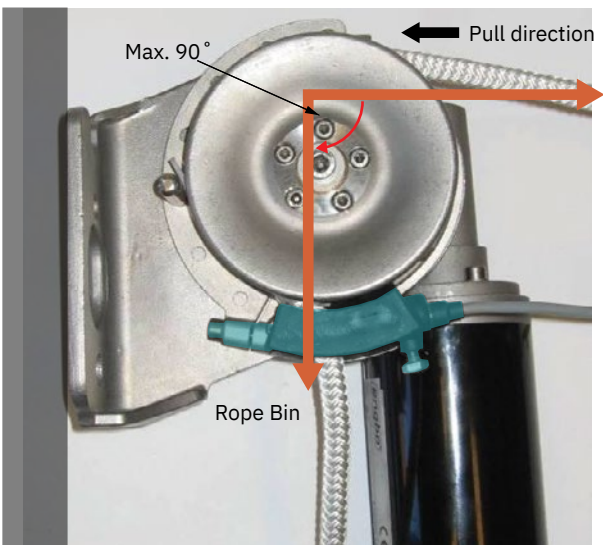

Windlass installed on the backside of an inboard cross bulkhead. The windlass mounting bracket has been rotated 180 degrees counter-clockwise

The rope is always pulled into the windlass from the right. This is because of the direction of rotation for the windlass gypsy wheel.

! Please refer to the graphic for special considerations relating to your model !

In order for the windlass to function normally, there must be a sufficient volume/ height below the windlass for stowing the rope when the anchor is up.

Recommended minimum height (A) below the windlass as well as width (B) and length (C) of the area used for stowing the rope.

Rope.	A (cm)	B (cm)	C (cm)
10 mm x 30 m	35	30	30
12 mm x 30 m	35	30	30
12 mm x 50 m	40	35	35

IMPORTANT

In case of installations where the rope is routed horizontally out of the windlass when the anchor is up, the relationship between A, B and C may vary. It is important that there is a sufficient volume to ensure that the rope is not forced into place below the windlass and cannot easily be pulled out by the line wheel.

Rope Stop Rings for Auto Stop

! Please refer to the graphic for special considerations relating to your model !

Under the rope guide there is an inductive sensor that signals auto stop when the anchor has been lifted all the way up. To activate the detector, two stop rings (included) are fitted on the rope.

The outer diameter of the stop ring must be as close to the outer diameter of the rope as possible. This is necessary in order for the inductive detector to be able to detect correctly.

In order to place the stop ring at the correct location on the rope, lift the anchor until the thimble eye is 25-50 cm below the rope roller (reel in at slow speed for the last section), and mark the rope with a marker at the location of the inductive sensor. The anchor is then reeled in at low speed to the desired final resting position. Mark the rope once more by the detector and fasten the stop rings by the marks.

These stop rings will be exposed to wear by the line wheel, especially during heavy loads, and must therefore be inspected regularly. Replace damaged stop rings if needed.

Recommended tools:

- Keeper ring pliers
- Pliers
- Auto stop rings (steel rings enclosed)

Rope Clearance

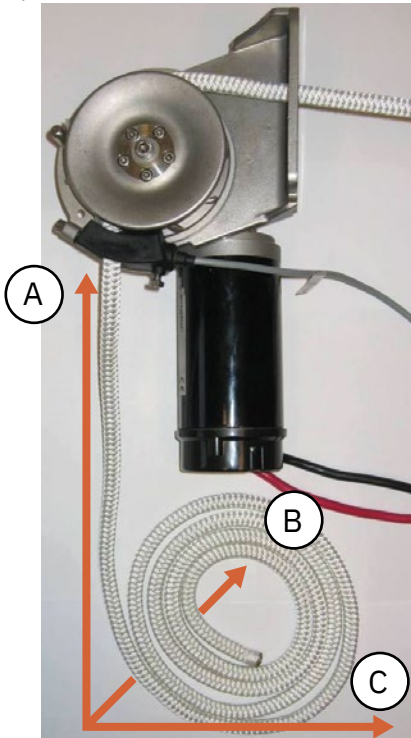

Stop Rings for Auto Stop

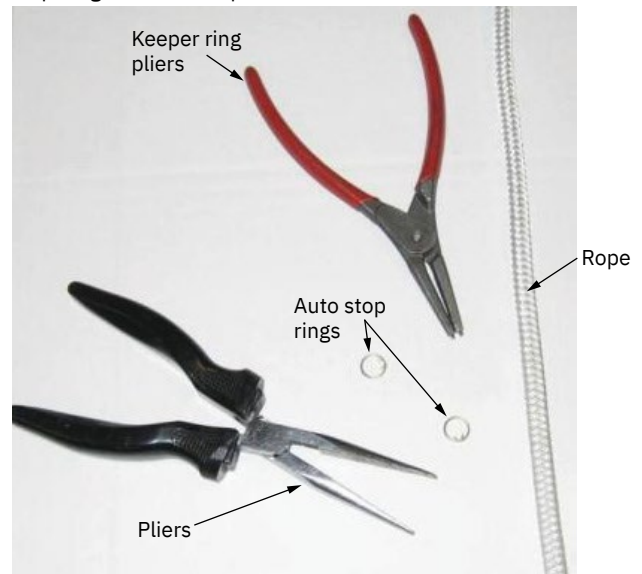

! Please refer to the graphic for special considerations relating to your model !

The enclosed steel rings (auto stop rings) are fitted in the locations where the windlass should slow down and then come to a full stop.

1. Open the stop rings with the keeper ring pliers.
2. Fit the ring over the rope.
3. Use the plier to pull the stop ring into place with the stop ring joint overlapping the opening and the ring fitted tightly around the rope.
4. Force the ends into the rope with the pliers to ensure the stop ring does not slip on the rope. **(NB: A fitted stop ring should look like this with closed windings and the ends secured inside the rope.)**
5. Stop ring fitted and fastened tightly to the rope. Fasten the other stop ring in the same manner.

1**2****3****4****5**

Visual Wiring Diagram

Cable size A, B and C:

if total length

A+B+C <10m: 25mm²

A+B+C >10m: 35mm²

To change motor direction:

Change cables D1 and D2 in control unit

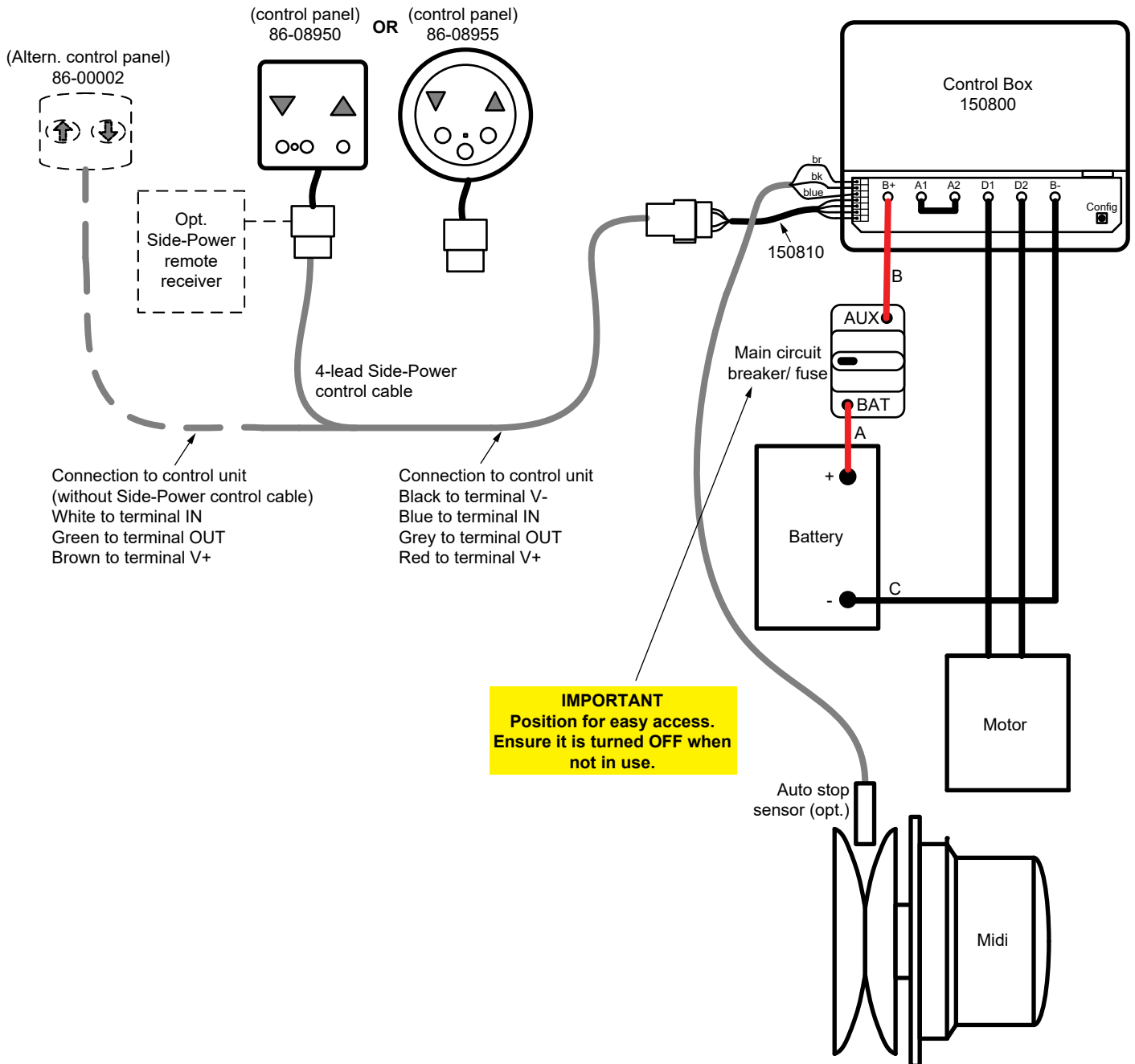

! Please refer to the graphic for special considerations relating to your model !

All kind of wiring and electrical fixing must be done with Main switch/ miniature circuit breaker turned OFF and no battery cables attached.

1. Connecting switch panel 86-08950 or 86-08955

- 1 pcs switch panel
- Cables are optional and come in various lengths.
- Cable is a 4-way Side-Power cable that easy can be attached to contact on control box unit.
- The cable must be attached to 150810 contact unit
- 150810 connection to control unit:
 - Black to terminal V-
 - Blue to terminal IN
 - Grey to terminal OUT
 - Red to terminal V+
- See wiring diagram or control panel manuals for more details
- Multiple panels can be fixed to the same control unit.

2. Switch panel 86-00002 (Discontinued)

- The panel comes with a self-adhesive surface, but if you prefer, you can use the corner holes to screw it firmly in position.
- Drill an hole (dia. 18 mm) in the place where the panel is to be fitted.
- Run the panel cable through the hole.
- Remove the protection tape from the rear surface of the panel and fix the panel firmly to the surface.
- Run the cable to the electronic control box.
- Cut off any surplus cable and strip the ends of the three wires that are to be connected to the terminal clips as described in the connection diagram. (See wiring diagram).

Connecting switch panel 86-00002 (Discontinued)

- The 3-way cable is connected like this:
- White to terminal IN
- Green to terminal OUT
- Brown to terminal V+
- See wiring diagram for details

3. Connecting the auto stop switch

Cables are connected like this:

4: Brown (BN)

5: Black (BK)

6: Blue (BU)

1



86-08950



86-08955

2



3



Auto Stop
main switch

! Please refer to the graphic for special considerations relating to your model !

Fitting control unit 150800

The unit is not water resistant or splash proof and must be placed in a dry area close to the windlass motor.

Use ring terminals of good quality with the correct size for the selected battery cables. Bolt hole should be 6mm. Tighten the terminals to maximum 5Nm.

Pay attention to assemble the terminal spacers and washers in the correct order according to figure 1.

The unit has mounts that ensures space between the unit and it's mounting surface. This to avoid condensation to enter the unit. It also ensures proper ventilation of the enclosure.

The control unit must be mounted with the cables protruding downwards.

Connecting the motor and battery cables on Midi

Motor for windlass type Midi is delivered with cables fitted to the motor.

- Fit included copper link(A1-A2 LINK) between Terminal A1 and A2.
- Connect the red cable from the motor to the Terminal marked D1/M+.
- Connect the black cable from the motor to the Terminal marked D2/M-.
- Connect supply cable from battery negative to the Terminal marked B-.
- Connect supply cable from breaker/ fuse to the Terminal marked B+.
- Connect breaker/ fuse to battery main switch.
- See complete wiring diagram on page 6 for reference.
- Tighten all terminals properly, including A1 and A2, with a maximum torque of 5Nm. Over-tightening may damage the terminals.
- Leave breaker/fuse disconnected until the installation is completed.

See control unit manual for configuring programming and more installation information.

fig.1

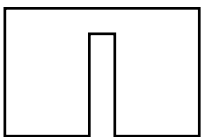
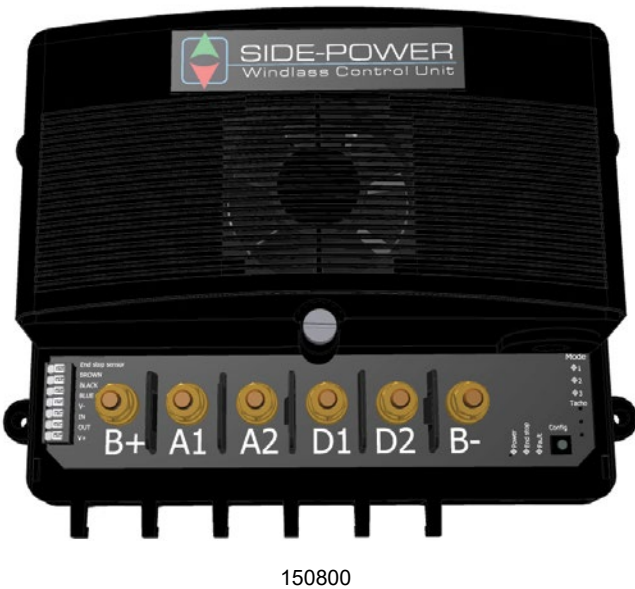

A1-A2 Link
see SM-111517 for illustration

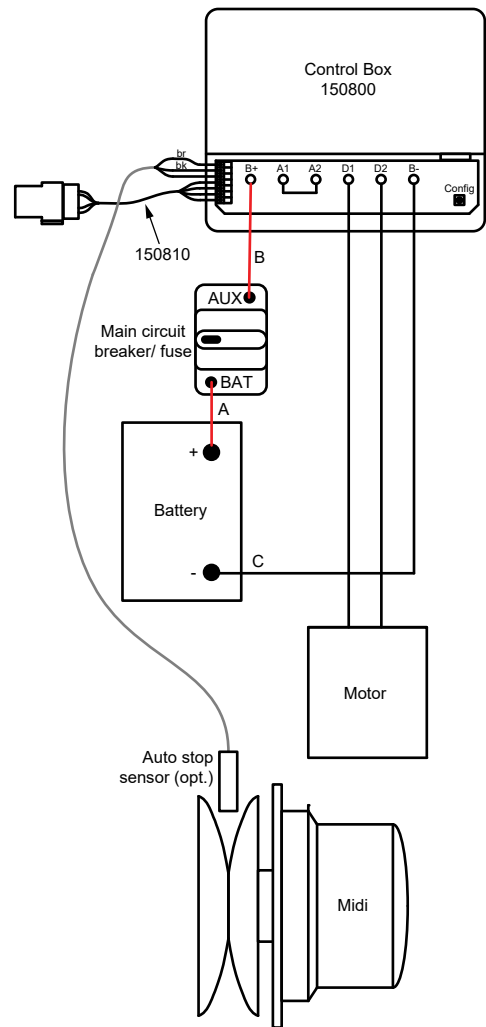

! Please refer to the graphic for special considerations relating to your model !

Main switch/miniature circuit breaker

119-00015(Midi 100-150A)

- MUST be used at all time in this installation
- Works as both MCB and main switch unit.
- The unit consists of one battery connection and one AUX connection. This is described on the unit. See wiring diagram for correct connection to battery and control box.
- Unit switched ON
 - To switch ON, move/press pin switch upwards.
- Unit switched OFF.
 - To switch OFF, press red the button.

WARNING

Improper use or incorrect connection of such high currents components will generate a lot of heat which in worst case can cause fire.

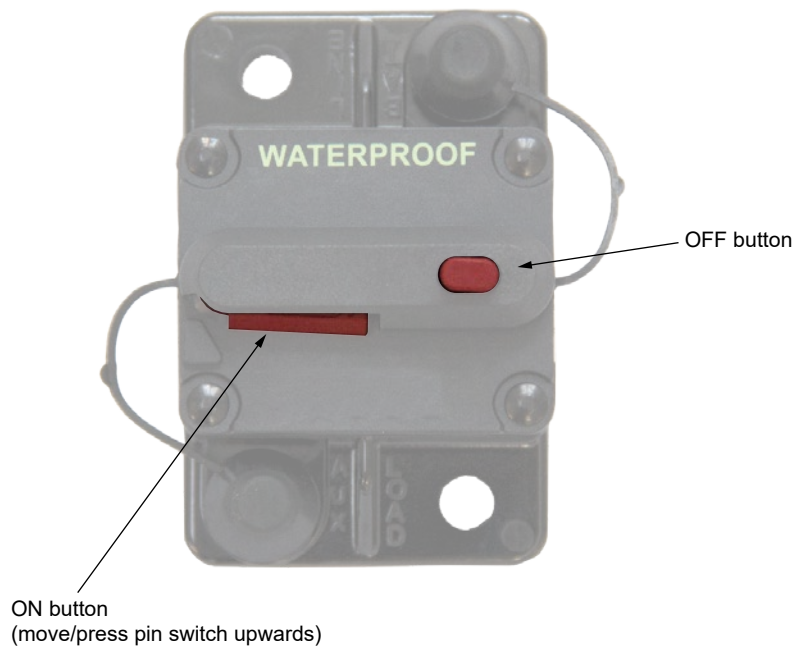

MG_0354

Find your local professional dealer from our certified worldwide network for expert service and support.

visit our website www.sleipnergrouper.com/support

Product Spare Parts and Additional Resources

For additional supporting documentation, we advise you to visit our website www.sleipnergrouper.com and find your Sleipner product.

Warranty statement

1. Sleipner Motor AS (The "Warrantor") warrants that the equipment (parts, materials and embedded software of products) manufactured by the Warrantor is free from defects in workmanship and materials for the purpose for which the equipment is intended and under normal use and service (the "Warranty").
2. This Warranty is in effect for two years (Leisure Use) or one year (Commercial and other Non-leisure Use) from the date of purchase by the end user (for demonstration vessels, the dealer is deemed as end user).
3. This Warranty is transferable and covers the equipment for the specified warranty period.
4. The warranty does not apply to defects or damages caused by faulty installation or hook-up, abuse or misuse of the equipment including exposure to excessive heat, salt or fresh water spray, or water immersion except for equipment specifically designed as waterproof.
5. In case the equipment seems to be defective, the warranty holder (the "Claimant") must do the following to make a claim:
 - (a) Contact the dealer or service centre where the equipment was purchased and make the claim. Alternatively, the Claimant can make the claim to a dealer or service centre found at www.sleipnergrouper.com. The Claimant must present a detailed written statement of the nature and circumstances of the defect, to the best of the Claimant's knowledge, including product identification and serial nbr., the date and place of purchase and the name and address of the installer. Proof of purchase date should be included with the claim, to verify that the warranty period has not expired;
 - (b) Make the equipment available for troubleshooting and repair, with direct and workable access, including dismantling of furnishings or similar, if any, either at the premises of the Warrantor or an authorised service representative approved by the Warrantor. Equipment can only be returned to the Warrantor or an authorised service representative for repair following a pre-approval by the Warrantor's Help Desk and if so, with the Return Authorisation Number visible postage/shipping prepaid and at the expense of the Claimant.
6. Examination and handling of the warranty claim:
 - (a) If upon the Warrantor's or authorised service Representative's examination, the defect is determined to result from defective material or workmanship in the warranty period, the equipment will be repaired or replaced at the Warrantor's option without charge, and returned to the Purchaser at the Warrantor's expense. If, on the other hand, the claim is determined to result from circumstances such as described in section 4 above or a result of wear and tear exceeding that for which the equipment is intended (e.g. commercial use of equipment intended for leisure use), the costs for the troubleshooting and repair shall be borne by the Claimant;
 - (b) No refund of the purchase price will be granted to the Claimant, unless the Warrantor is unable to remedy the defect after having a reasonable number of opportunities to do so. In the event that attempts to remedy the defect have failed, the Claimant may claim a refund of the purchase price, provided that the Claimant submits a statement in writing from a professional boating equipment supplier that the installation instructions of the Installation and Operation Manual have been complied with and that the defect remains.
7. Warranty service shall be performed only by the Warrantor, or an authorised service representative, and any attempt to remedy the defect by anyone else shall render this warranty void.
8. No other warranty is given beyond those described above, implied or otherwise, including any implied warranty of merchantability, fitness for a particular purpose other than the purpose for which the equipment is intended, and any other obligations on the part of the Warrantor or its employees and representatives.
9. There shall be no responsibility or liability whatsoever on the part of the Warrantor or its employees and representatives based on this Warranty for injury to any person or persons, or damage to property, loss of income or profit, or any other incidental, consequential or resulting damage or cost claimed to have been incurred through the use or sale of the equipment, including any possible failure or malfunction of the equipment or damages arising from collision with other vessels or objects.
10. This warranty gives you specific legal rights, and you may also have other rights which vary from country to country.

Patents

At Sleipner we continually invest to develop and offer the latest technology in marine advancements. To see the many unique designs we have patented visit our website www.sleipnergrouper.com/patents

© Copyright Sleipner Motor AS, 2021

The information given in the document was correct at the time it was published.

However, Sleipner Motor AS can not accept liability for any inaccuracies or omissions it may contain. Continuous product improvement may change the product specifications without notice.

Therefore, Sleipner Motor AS can not accept liability for any possible differences between product and document.

Register your product and learn more at www.sleipnergroun.com



SLEIPNER AS

P.O. Box 519

N-1612 Fredrikstad

Norway

www.sleipnergroun.com

Made in Norway

