



Installation Guide

For Vector Fin Stabiliser Systems

STABILISER 55B

VECTOR FINS VF650, VF800



SLEIPNER MOTOR AS

P.O. Box 519

N-1612 Fredrikstad

Norway

www.sleipnergroupp.com

DOCUMENT ID: 525I

REVISION: 5

DATE: 2022

LANGUAGE: EN

MI

Contents

Installation Manual

Responsibility of the Installer.....	3
General Installation Considerations and Precautions Guidelines	3 - 4
Addition Supporting Manuals.....	5
Key Components	6
Actuator Measurements	7
Vector Fin Measurements.....	8
Measurement Clearance	9
Hull Forces	10
Fin Positioning	11 - 13
Fin Modification Tunnel ends.....	14
Mechanical Installation	15 - 19
Hydraulic Installation	20 - 27
Electrical Installation.....	28 - 35
S-Link System Description	36
Electrical Installation.....	37 - 41
Fin Installation	42 - 49
Fin Location Label	50
Fin System Interface.....	51 - 52
Start-Up	53 - 59
Sea Trial	60 - 61
Fin Removal	62
Installation Checklist.....	63 - 64
Service and Support.....	65
Product Spare Parts and Additional Resources.....	65
Warranty Statement.....	65

Failure to follow the considerations and precautions can cause serious injury, damage and will render all warranties given by Sleipner Motor as VOID.

MC_0411

Responsibility of the Installer

MC_0038

The installer must read this document to ensure necessary familiarity with the product before installation.

Instructions in this document cannot be guaranteed to comply with all international and national regulations. It is the responsibility of the installer to follow all applicable international and national regulations when installing Sleipner products.

The recommendations given in this document are guidelines ONLY, and Sleipner strongly recommends that advice is obtained from a person familiar with the particular vessel and applicable regulations.

This document contains general installation instructions intended to support experienced installers. If you are not skilled in this type of work, please contact professional installers for assistance.

If required by local regulation, electrical work must be done by a licensed professional.

Appropriate health and safety procedures must be followed during installation.

Faulty installation of Sleipner products will render all warranties given by Sleipner Motor AS.

General Installation Considerations and Precautions Guidelines

MC_0440

For stabiliser systems

MC_0203

Reducing the roll of the boat, and how efficiently fins achieve this will depend on several factors.

- First, the size of the fins compared to the boats "stabilizing requirements".
- Fin positioning on the hull which in turn decides the angle they work.
- Leverage arm length around the vessel centre of gravity.

The bigger the stabilizer fins, the more boat roll is reduced. There are limitations to the size of fin stabilizers you can install depending on the size of the boat. Limitations are typically decided by:

- space requirements compared to available space in the boat,
- Added drag and potential speed loss

The typical/ default size recommendation is calculated based on the provided data to reduce the roll at your chosen "minimum stabilizing speed" of approximately 5 degrees. **(NB: that this is not a guaranteed figure as there many factors that could affect performance at varying speeds.)**

The "AnySpeed", "zero speed" or "at anchor" stabilization, is by default calculated to reduce the roll by approximately 4 degrees.

Please follow this general guide for steps to prepare and plan your installation process:

- Find the best possible position of the fins based on the information provided in the sections about:
- Safety and General precautions Measurements.
- Please note the very flexible installation methods possible including off-set angle installation.
- Possible with Sleipner stabilizers as this might enable installation in positions more suited and efficient than possible with some other brands or types of fin stabilizers.
- Fin positioning
- Hull forces
- Ensure that it is space to do the reinforcement of the hull if necessary

Plan the installation of the hydraulic parts including hose/pipe runs based on the information provided in the sections:

- Basic hydraulic installation
- AC power pack
- Noise considerations
- Relevant hydraulic diagram with hose specifications for your particular system

Plan the installation of the electrical parts including the control panel and wiring runs based on the information in the sections:

- Power supply
- S-link wiring
- Control panel installation

Your Sleipner representative will be able to help make an educated decision for what is the best solution for your boat and your preferences. Before starting the installation the Sleipner representative can ensure that you are not installing parts and products that will not meet your expectations.

For stabiliser systems

MC_0302

Sleipner Motor AS is a manufacturing company of marine equipment and not a Naval Architectural company & therefore take no responsibility in regards to the installation of our products onto seagoing vessels. This includes any requirement for the vessels:

- hull reinforcement.
- Change in the vessel's stability.
- Dynamic performance.
- Weight and moment.
- Noise proofing.
- Watertight integrity after installation during normal operations or in the event of a collision.

It is the responsibility of the installer/boat builder to determine hull reinforcement requirements, ensuring that sufficient strengthening measures are in place & the vessel's hull will withstand & maintain watertight integrity in the event of a collision of our product, impacting an object when the vessel is underway.

IMPORTANT

The installer must use the Hydraulic system manual and specific system manual as a supplement to ensure necessary knowledge to complete the installation.

The stabilizer product includes heavy parts. Ensure suitable lifting and support equipment is available during installation & removal to prevent material damage or personnel injury.

During yacht lifting operations:

- Ensure the stabilizer fins are in the locked/neutral position.
- Lifting personnel are informed that stabilizer fins are installed preventing the danger of snagging the lifting slings & damage to the yacht, its equipment or injury to personnel.

Yacht transportation overland with road vehicles may require the removal of the stabilizer fins & shafts. Please contact Sleipner representatives for instruction procedures.

Do not remove the equipment orifice protection blanks or covers until ready for use, preventing the ingress of undesired contamination.

(NB: Hydraulic operated equipment must be clean and debris free at all times.)

Avoid applying anti-corrosion protection lubricants to the hydraulic actuator cylinder rods as this can attract dirt and debris causing oil leaks due to damaged seals. On completion of the installation and yacht launch thoroughly check for leakages & the yachts hull watertight integrity is maintained.

WARNING

Ensure electrical & hydraulic power is switched off before any servicing work is carried out on the stabilizer system.

With power, the Stabilizer systems with 'at anchor' function installed & 'Auto' selected can suddenly operate & move without warning.

Hydraulic equipment (including Nitrogen pressure-filled accumulator) operates at high pressure. Ensure that all system pressure is released before carrying out any servicing work. Never carry out any welding, soldering or mechanical work on the accumulator unit.

For special yacht design stabilisers

MC_0302

Provide servicing access hatches to stabilizer actuator assemblies for the removal & installation of Stabilizer fin shafts if & when required.

When the Stabilizer System 'At Anchor' function (optional) is installed, position and soundproof the hydraulic power pack (AC generator & pump), the actuator assembly compartments and hydraulic hoses, to ensure excess noise will not disturb sleeping passengers.

Ensure provisions to maintain the yachts watertight integrity in the event of a fin collision.

Follow the addition of supporting manuals to aid in the installation process of this product.

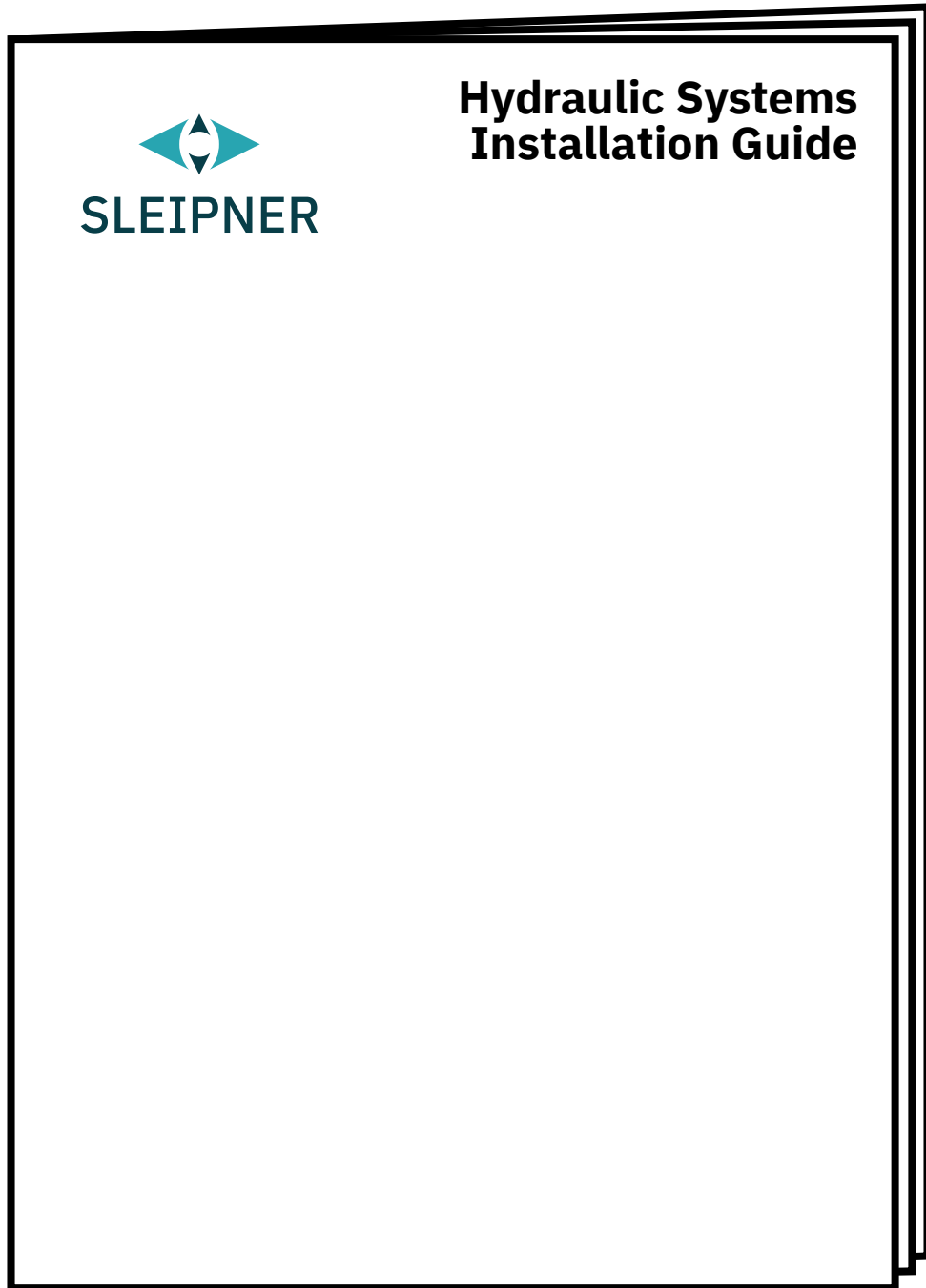

Key Components

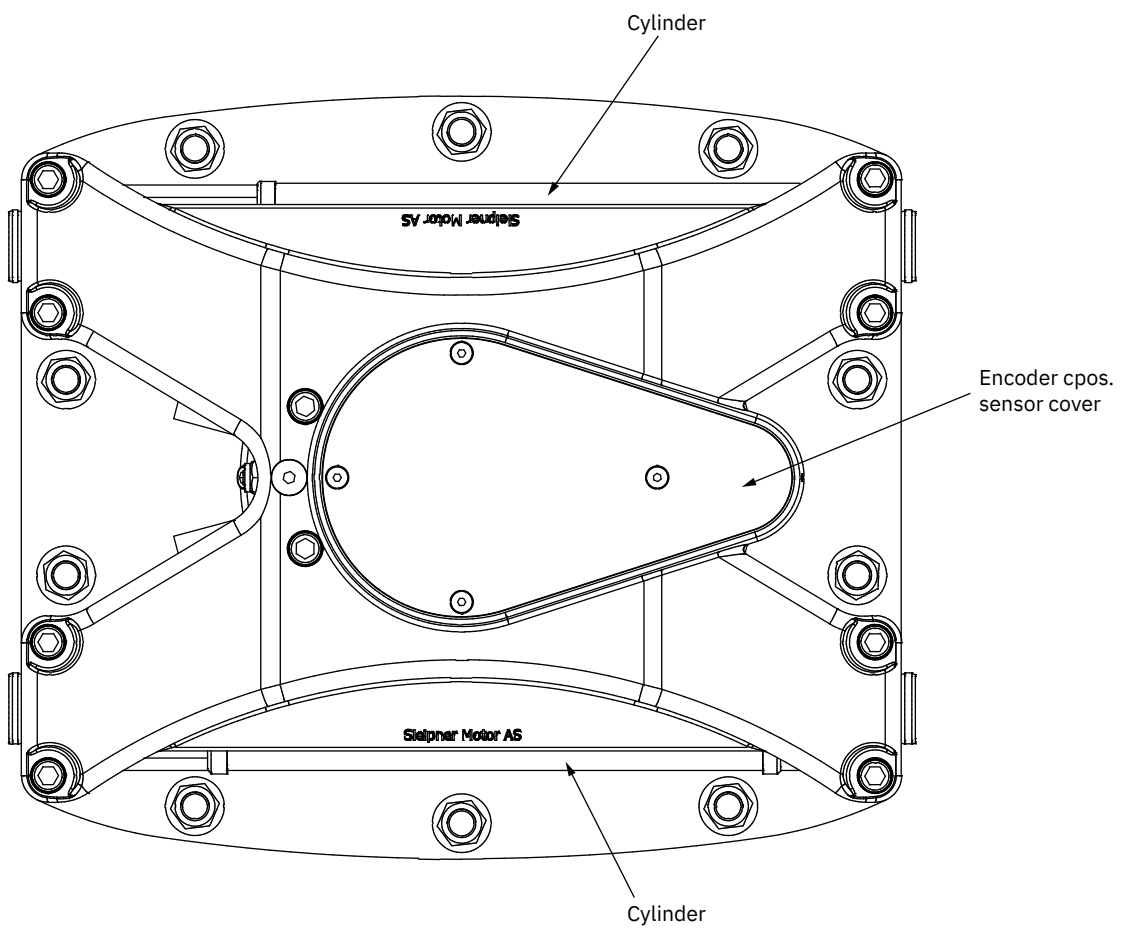
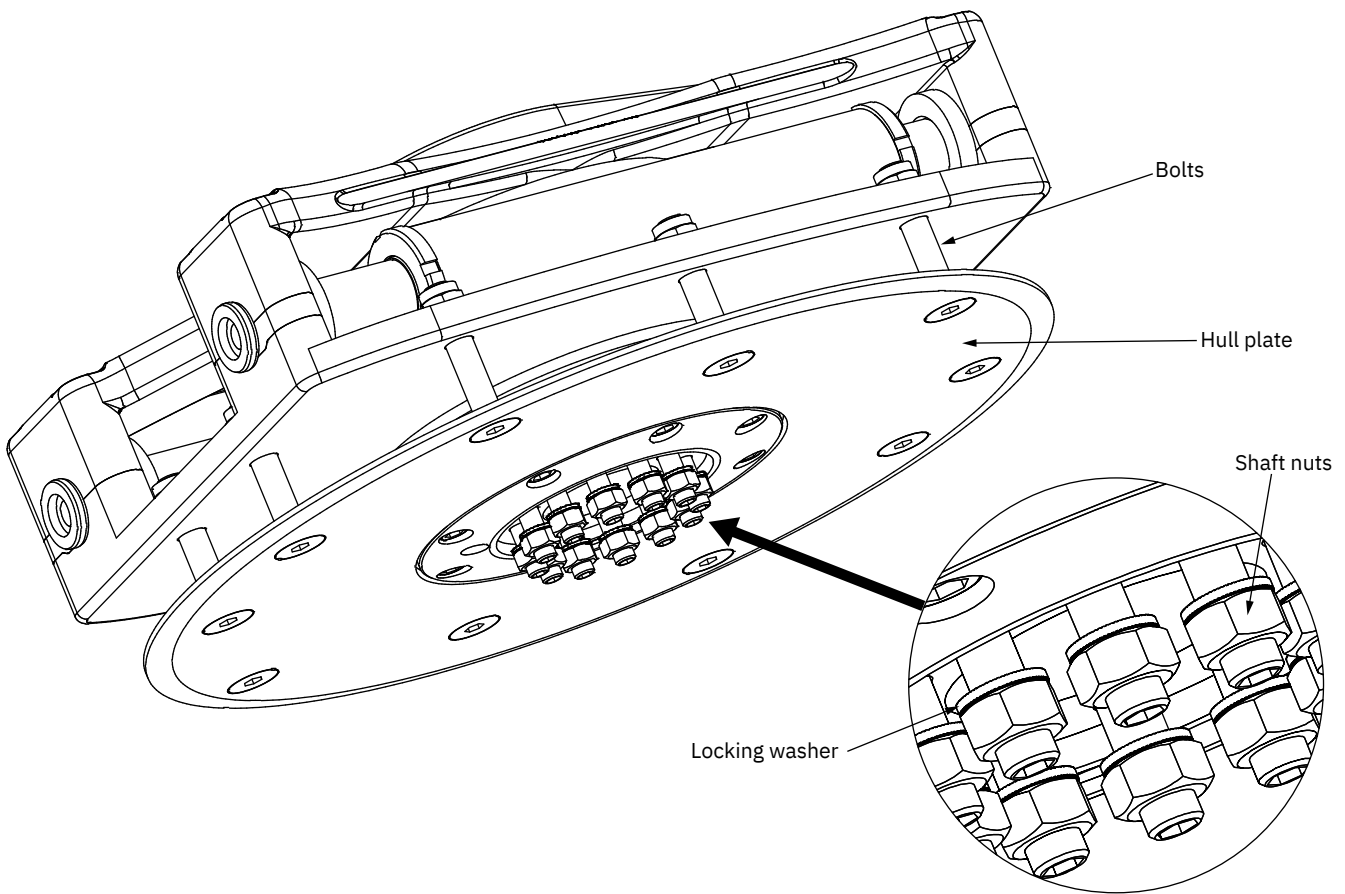

Measurement code	Measurement description	*55b	
		mm	inch
A	Actuator Length (+60mm fitting in both ends)	510	4.33
B	Actuator Width	430	0.16
C	Actuator height inside the hull	149.5	4.65
D	Total actuator height	198.5	4.17
E	Diameter of the actuator base plate	550	5.10
F	Hull thickness +0 / -3mm tolerance (sealant included)	49	4.33

The fin actuator assembly may be installed in any convenient radial 360° position in the hull.

IMPORTANT

Consider and plan the positioning/orientation of the actuator to achieve the full fin range of movement in both directions. Also, ensure to achieve the correct fin alignment parallel to the keel of the yacht.

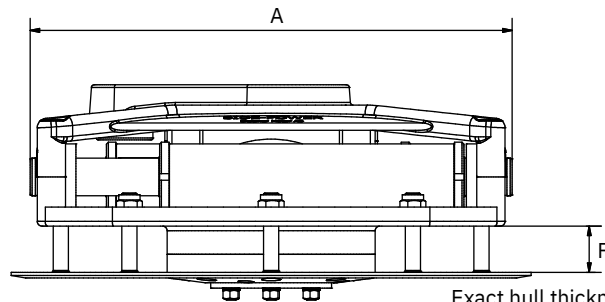
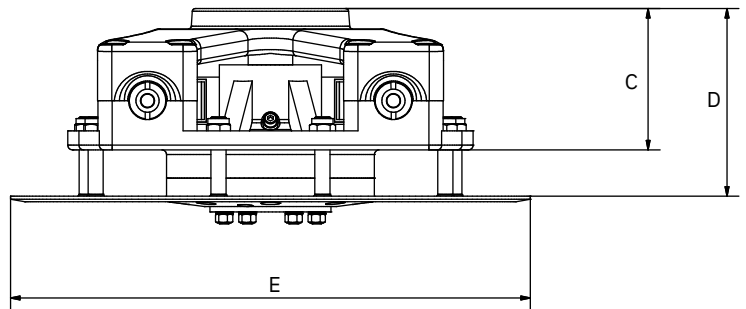
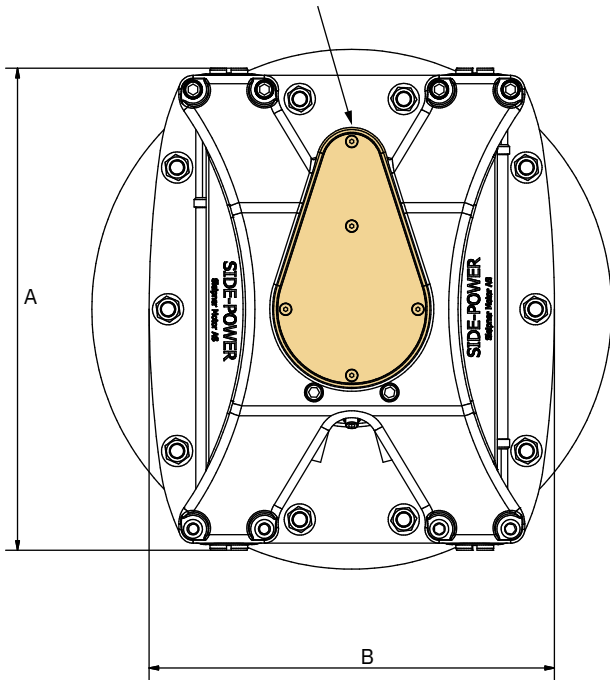

Exact hull thickness
When inside is finished it must be absolutely flat and average parallel to outside hull:

Measurement Clearance

Important
Ensure that all equipment with physical functions (actuators, valves, electrical & hydraulic connection points) are installed to allow space in the boat for service, maintenance and repair access as per the following illustrations. This is the installer/boat builders full responsibility

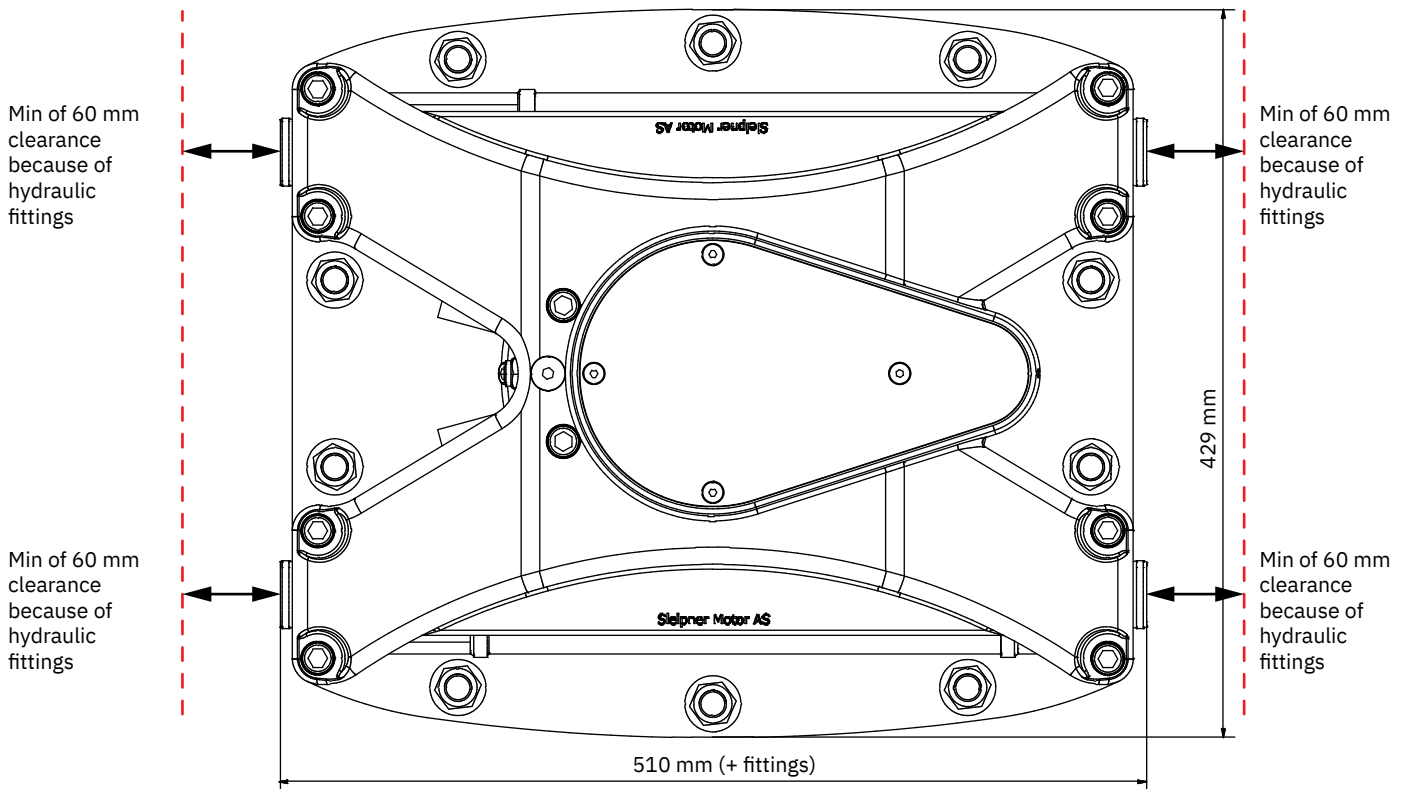
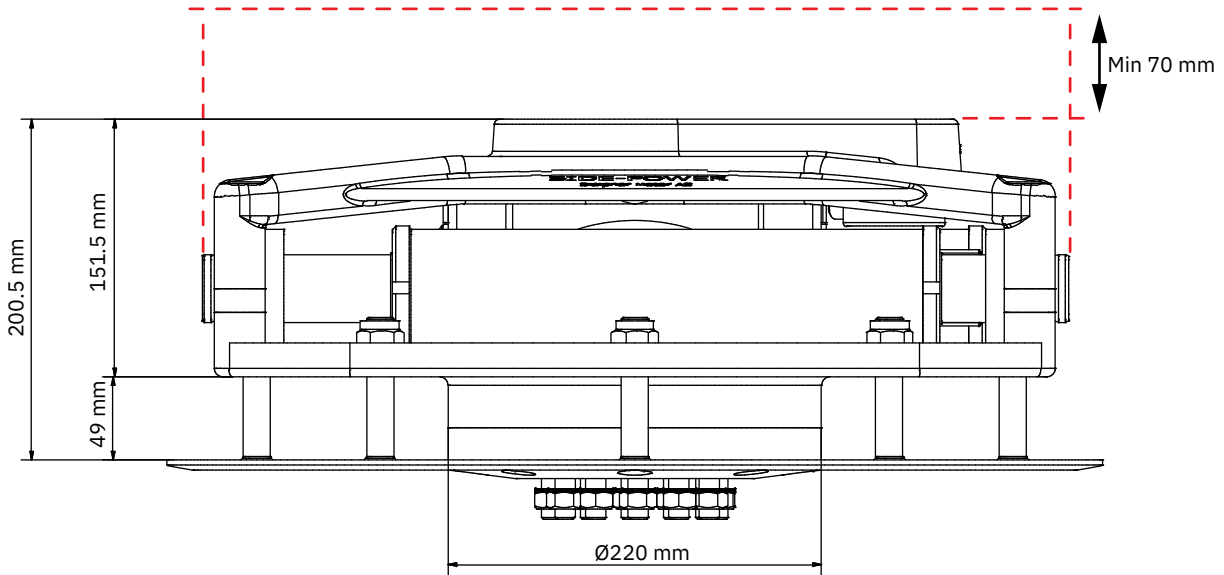

All calculated values are normalised, determined by equilibrium considerations and also that various coefficients are inaccurate as hull design etc will affect the actual fin effect.
 Dynamic effects such as jumps/impacts with waves, back flow closing of valve etc could further increase the hull/shaft loads. Therefore all dimensioning should account for this by using a safety factor.

The aft top face of the fin is deliberately made weaker than the rest of the fin so it will break easier in case of an impact with the hull.

It is advised to strengthen the hull or ensure it is manufactured with materials suitable to sustaining impacts over the total length of the fin within an area of approximately 10 degrees of fin rotation in each direction from its centre.

(NB: This is a safety measure to ensure the fin will not break through the hull in a collision situation.)

Sleipner curved Vector Fin design comes with additional benefits in hull safety. Any impact with the ground will not only bend the shaft backwards and outward, allowing the fin to break away with less stress on the hull.

SPS55

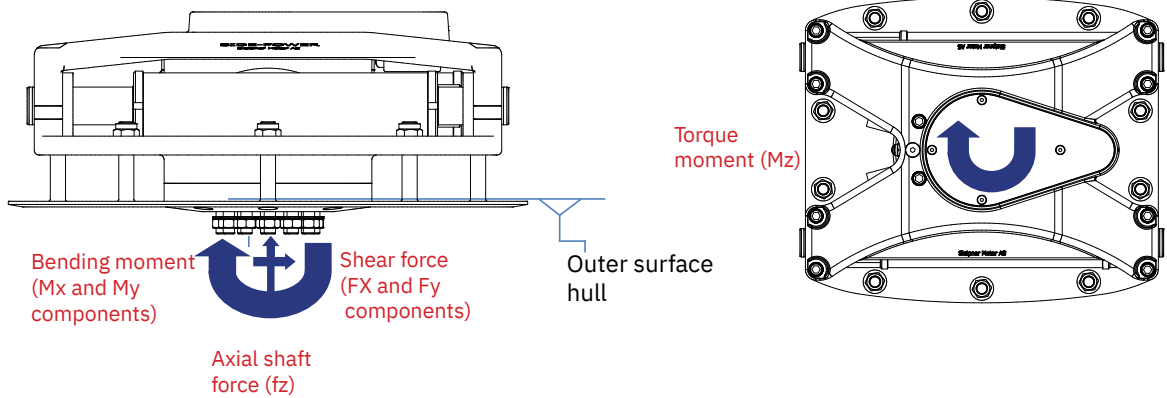

FIN LOADS ON HULL						
Fin size	Speed	Bending moment (Mx+My)	Twisting torque (Mz)	Axial shaft (Fz)	Shear force (Fx+Fy)	Shaft break - away
SPS55 VF 650	10 kn / Min	3500 Nm	2100 Nm	3200 N	9500 N	230 kN
	15 kn	4700 Nm	2700 Nm	5300 N	10800 N	230 kN
	20 kn	5600 Nm	2700 Nm	6400 N	11800 N	230 kN
	25 kn	6400 Nm	2700 Nm	7300 N	12700 N	230 kN
	30 kn	6600 Nm	2700 Nm	7800 N	15000 N	230 kN
	35 kn	6600 Nm	2700 Nm	7800 N	18000 N	230 kN
	40 kn	6600 Nm	2700 Nm	7800 N	18000 N	230 kN
SPS55 VF 800	10 kn / Min	4400 Nm	2700 Nm	4000 N	9300 N	230 kN
	15 kn	5000 Nm	2700 Nm	5200 N	10000 N	230 kN
	20 kn	6200 Nm	2700 Nm	6300 N	10500 N	230 kN
	25 kn	7100 Nm	2700 Nm	7300 N	12100 N	230 kN
	30 kn	7300 Nm	2700 Nm	7800 N	14000 N	230 kN
	35 kn	7300 Nm	2700 Nm	7800 N	19000 N	230 kN
	40 kn	7300 Nm	2700 Nm	7800 N	19000 N	230 kN

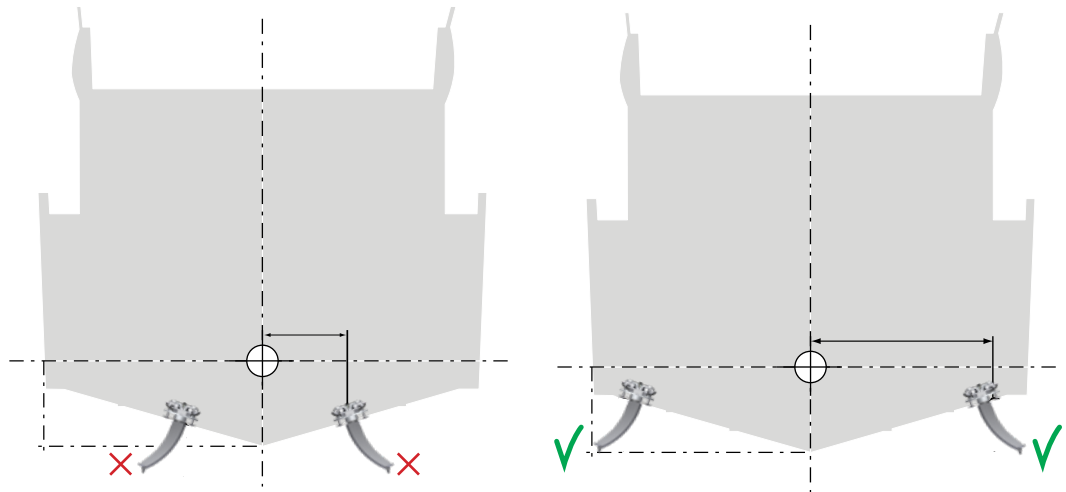

Fins should not extend outside the beam or below the keel when in neutral position.

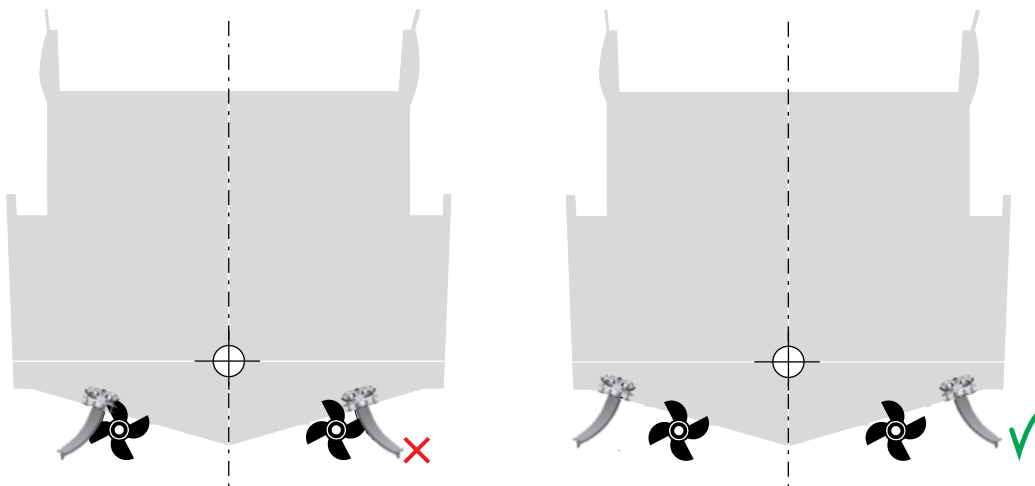

Fins should be placed as far outboard as possible, and NOT in-line with the propellers, to ensure avoiding possible disturbance of the water flow to the props which in the worst case can cause vibrations / cavitation.

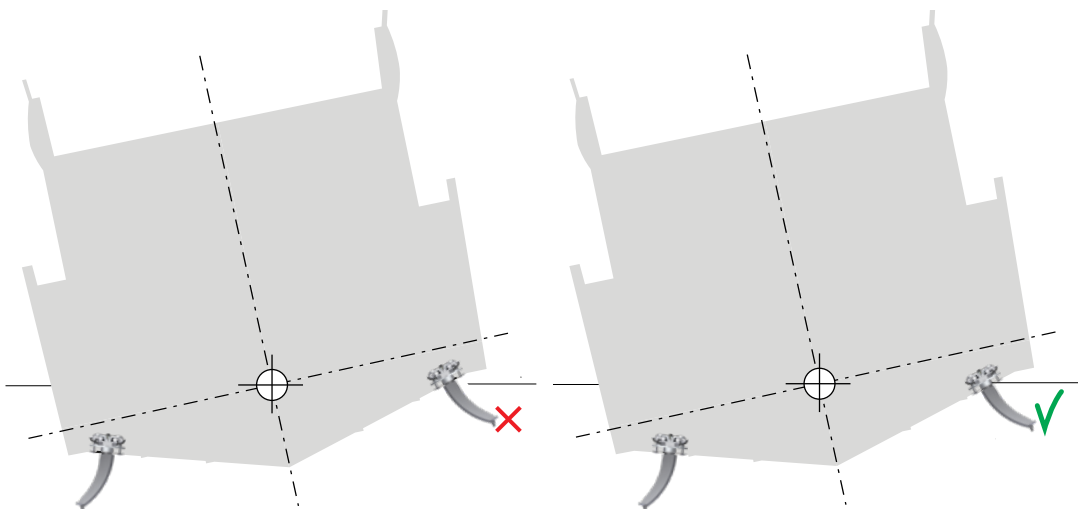

No part of the fin should be above water level during normal roll motion/under normal sea conditions.

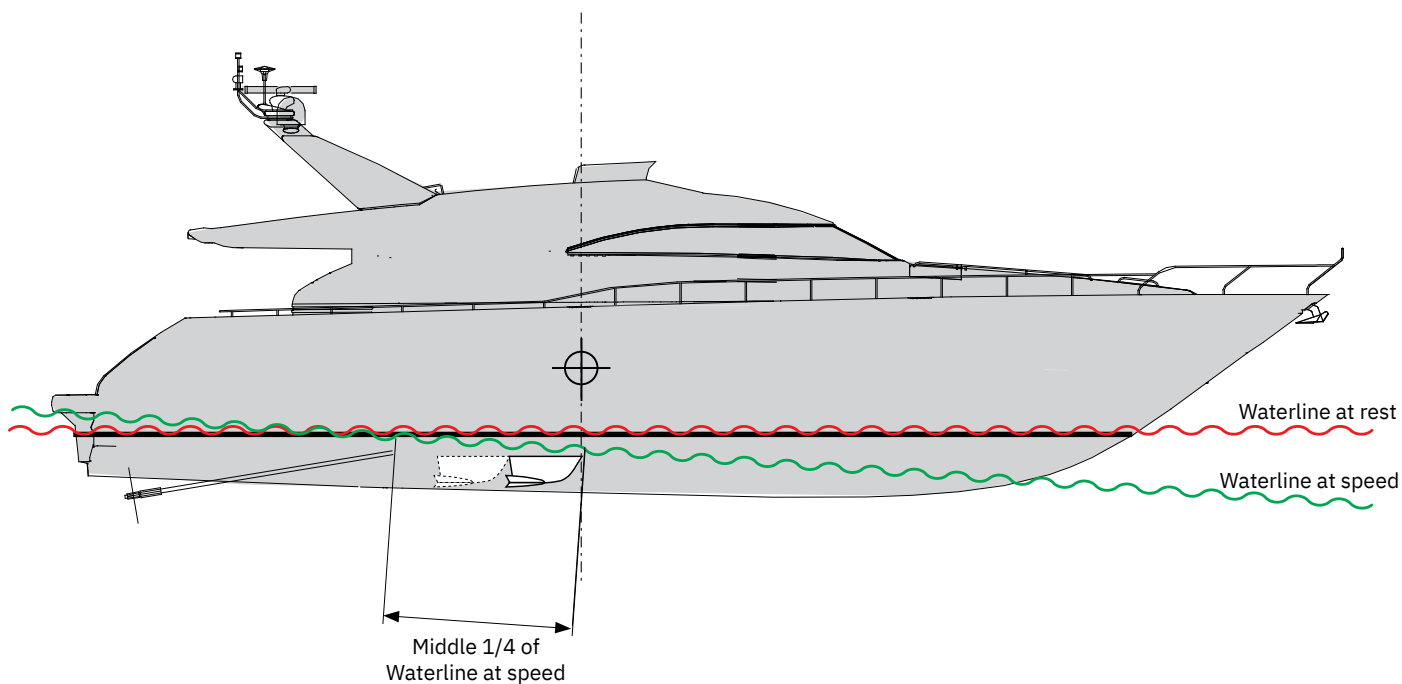
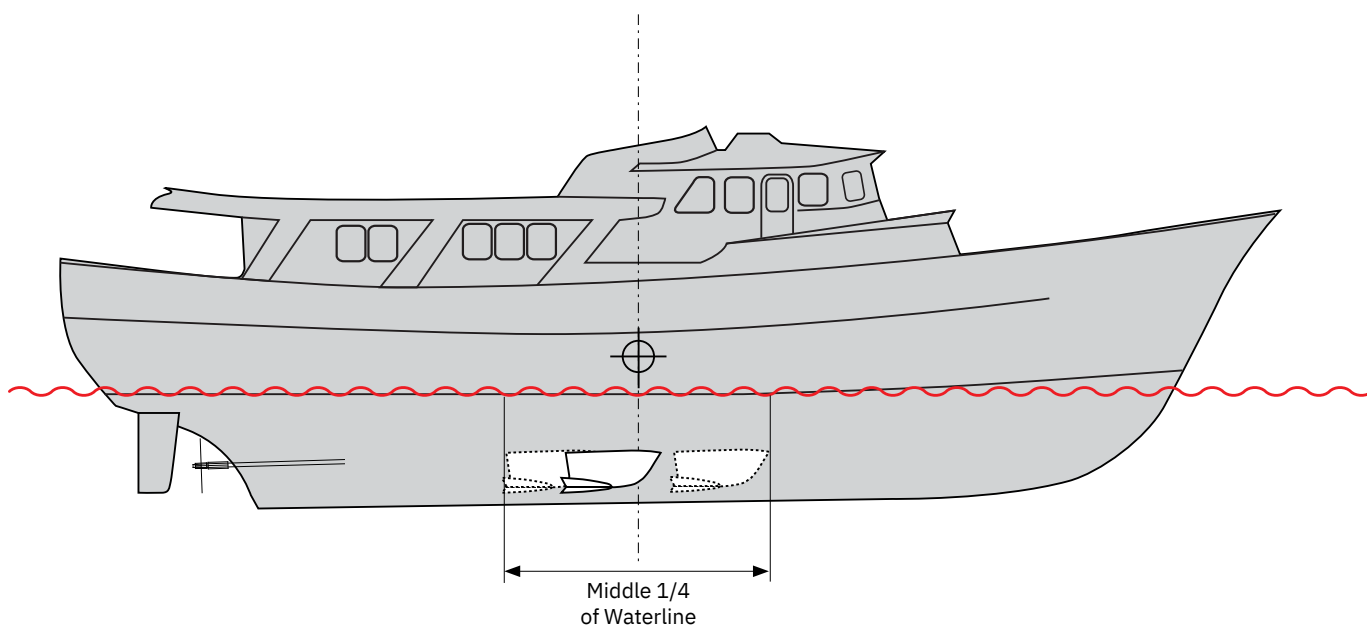

To avoid unwanted influences on the steering characteristics, the fins should be placed close to the vessel longitudinal centre of gravity (LCG)
 - If unknown, this is usually a little aft of 50% of the waterline length.

For high speed vessels, the fins should be placed with trailing/leading edge within middle 1/4 of waterline length at speed and not in front of the LCG.

For vessels with top speed under 15 knots, fin may be placed within the middle 1/4 of waterline length.

IMPORTANT

These are general guidelines and some hull types might allow for an installation position outside of this recommendation.

Transversal fin positioning of Vector Fins™

With Vector fins™ it is a priority to push the fins as far outboard as possible to achieve the most leverage for the fins forces unlike standard fins.

With Sleipner stabilizers enable installation of the fins to have different stroke angles inboard and outboard as the locked centre and cruising centre is flexible because they are locked hydraulically.

Avoid cutting off any of the back top section of the fin (normal on most fins on hard-chine boats) as this will cause added resistance/ drag by the fin. **(NB: Common on fins on hard-chine boats)**. This will create a recess area that will allow water at higher speeds and anchor stabilization to lose force also as part of the water will pass easier between the hull and the fin. Additional due to the outward "bend" of the fins keeping the lower part inside the boats "envelope" it will result in the upper part of the fins being further inboard that creates less of an outboard stroke in the upper part of the fin (along the hull).

Finding the best position for the fin and actuator positioning often is related to the inside configuration and space that is required for proper installation.

General Rules:

–Push the actuators as far as possible outboard, keeping at least 22 degrees of outboard stroke as a minimum **(NB: if less, and the lower part is within boat envelope, a small cut-away of the back upper part can be done as a compromise)**.

It is also acceptable installing the fins further inboard If inside configuration/ access to inside parts of actuators is required. **(NB: Performance will be reduced slightly due to less leverage arm for the stabilizing force applied by the fins.)**

Measurements along hull bottom outwards to chine(upper) and outside boat "envelope" (lower) in mm, center shaft to chine start / outside envelope:

Fin size	At maximum: 38°		At minimum : 22°	
	Upper	Lower	Upper	Lower
VF650	575	810	350	625
VF800	642	900	390	695
VF1050	731	1016	444	791
VF1350	828	1150	504	897
VF1650	914	1305	557	1001
*VF1950	*991	*1386	674	1112

"Boat" view

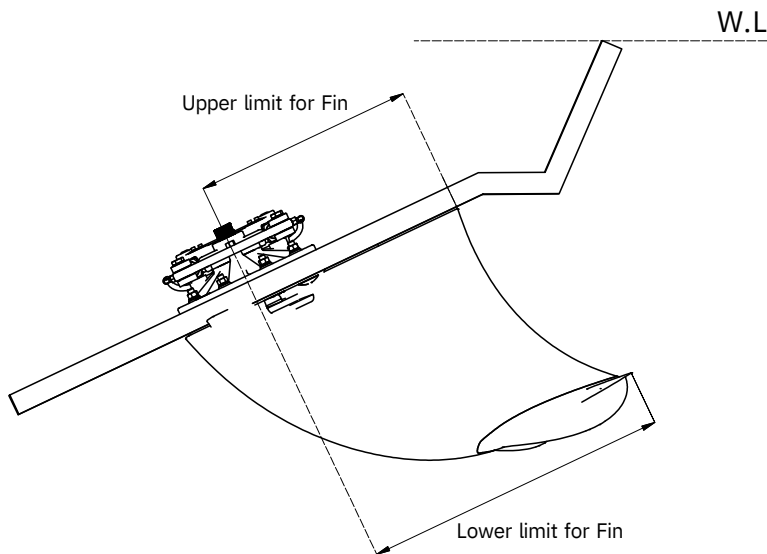

"Top" view

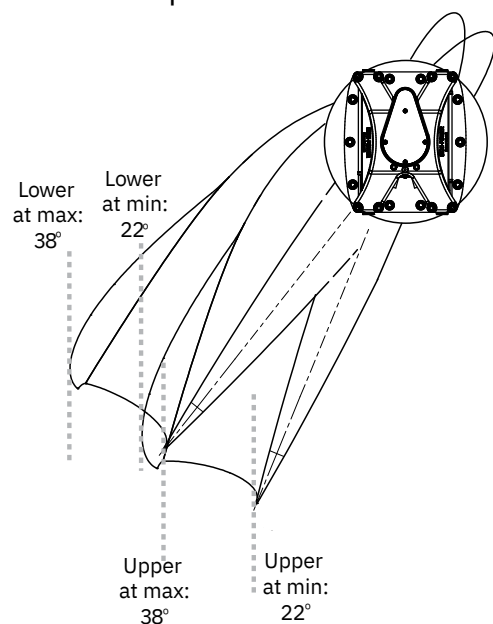

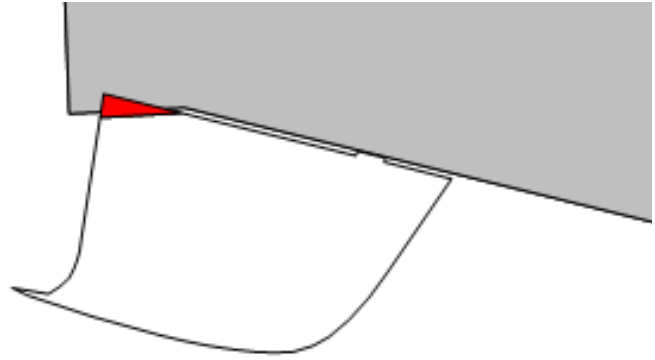

In case of the fin positioning being so that you need to cut down some of the top aft end of the fin to avoid it hitting the hull (very typical on planning boats with hard chines), please do so as per the instructions below.



Section Through Fin



The fins are made with a pre-molded foam core with a vacuum injected Vinylester skin.

1/ Cut away the desired area – “dig” / cut out the foam core 7mm all the way along the cut area – but approx. 18mm at the edges.



Section Through Fin

2/ Fill this with epoxy filler, level with the fin outer skin. Grind the GRP back on the fin top edges to allow mat to be applied flush later on.

Section Through Fin

3/ Then apply a couple of layers of GRP mat and epoxy over the top and onto the external skin. The GRP should then be sanded/ground flush with the original surface. The repaired surface should be primed with the customers choice of Anti-foul paint prior to the Application of the final coats of Anti-foul.

! Please refer to the graphic for special considerations relating to your model !

IMPORTANT

Reinforce the hull for the stabilizer installation in accordance with a naval ships architects recommendations.

Define the optimal position of the stabilizer fins.

1. Drill a 21mm pilot hole at the fin shaft centre line position externally through the yachts hull.
2. Using the pilot hole as centre line mark and cut a Ø230 mm diameter hole from inside the boat using a suitable cutting Jig & tool.
3. Adjust the surrounding hull to a thickness of 49mm (Sealant included) (SPS55B) and ensure that the internal and external surfaces are parallel and flat.

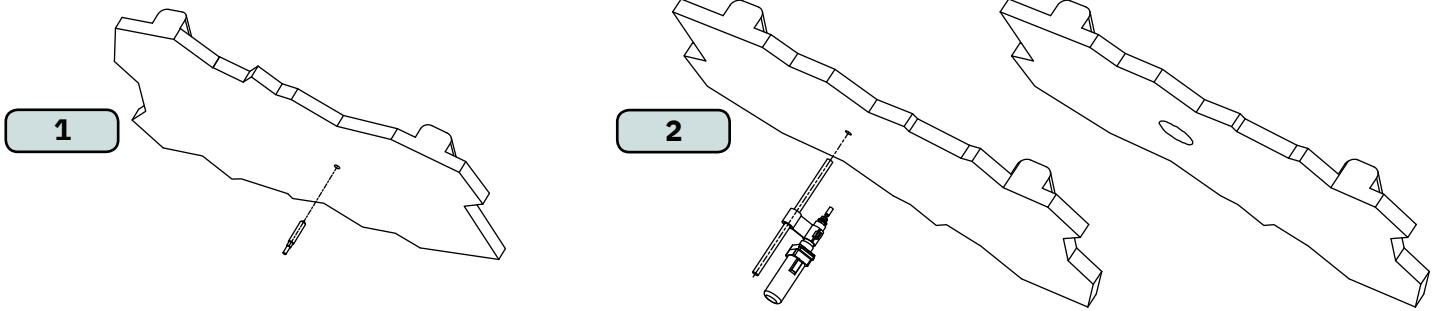

3

Remove or build up the surrounding area to reach a thickness of 49mm

IMPORTANT
Tolerances for the hull thickness is +0/-3mm - the thickness of the hull must NOT be larger than 49mm.

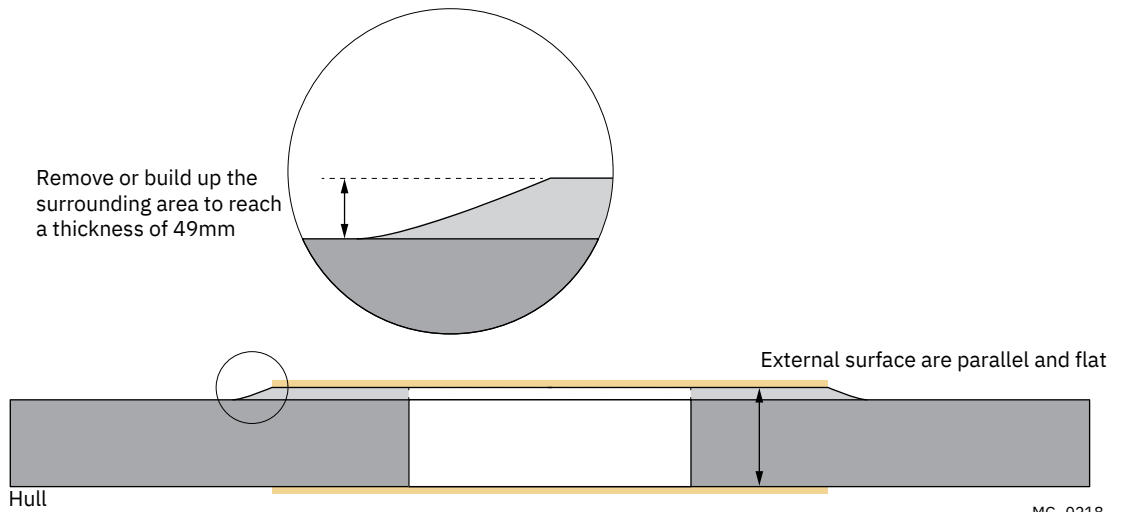

! Please refer to the graphic for special considerations relating to your model !

1. Mark the positions of the holes for the securing bolts. **(NB: Use the external securing plate as a template.)**
2. Cut & drill the holes using appropriate cutting and drilling equipment.
3. Apply a moderate coating of watertight sealant to the mating surface. **(NB: Sealant must be compatible with hull material. A naval architect/ Boat builder must confirm this.)**

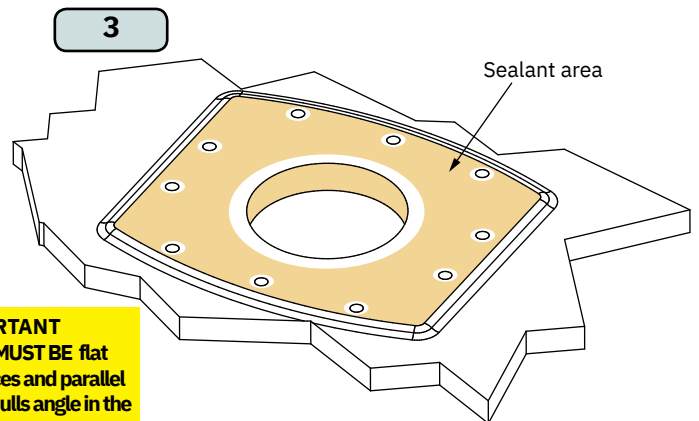
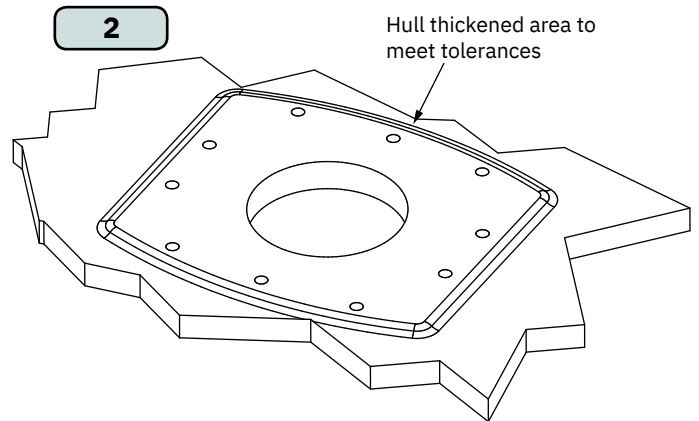
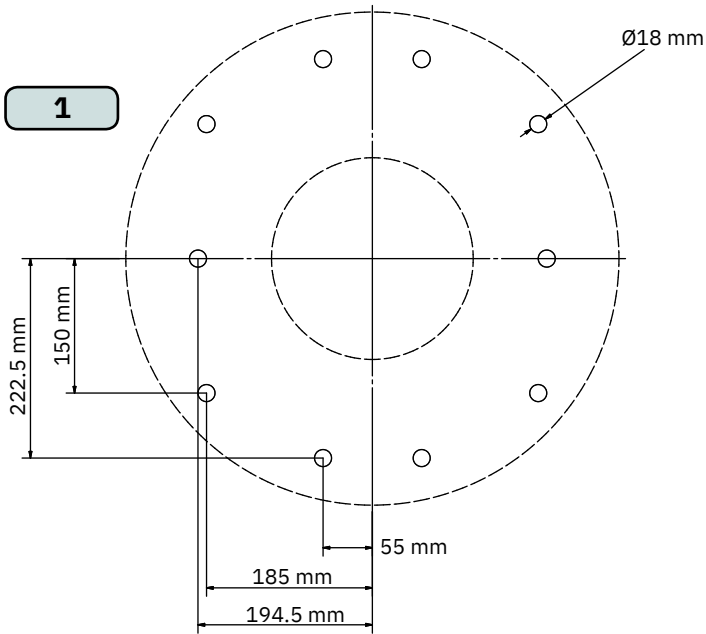

IMPORTANT
The surface **MUST BE** flat within tolerances and parallel with the outer hulls angle in the centre of the actuator.

! Please refer to the graphic for special considerations relating to your model !

MOUNTING OF THE STABILIZER ACTUATOR ASSEMBLY

1. Carefully lower the Stabilizer Actuator Assembly into the hulls actuator hole in the correct orientation to the sealant mounting surface.
2. Use two of the securing bolts to temporarily lock the Actuator Assembly into position.
3. Countersunk all holes to allow space for bolt heads and sealant without damaging the hull.
4. Apply sealant in the gap of the centre hole in the hull to the Actuator shaft core.

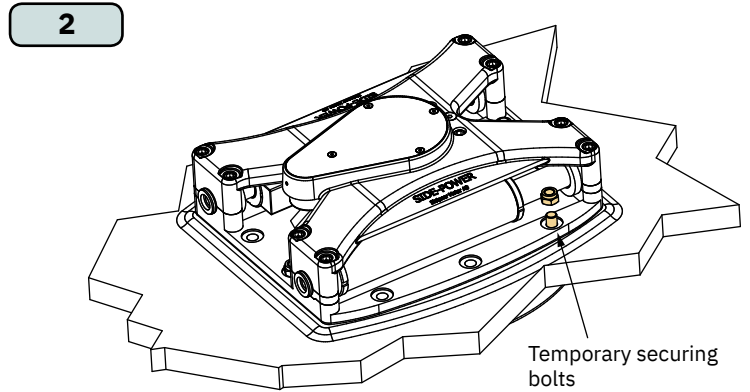
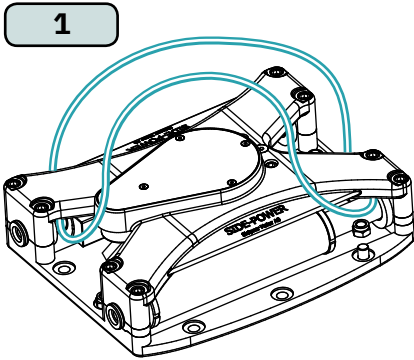

IMPORTANT
 Use appropriate lifting equipment (for example a sling) to lift the Stabilizer Actuator.
 DO NOT lift or attach lifting equipment to the actuating cylinders or their rams.

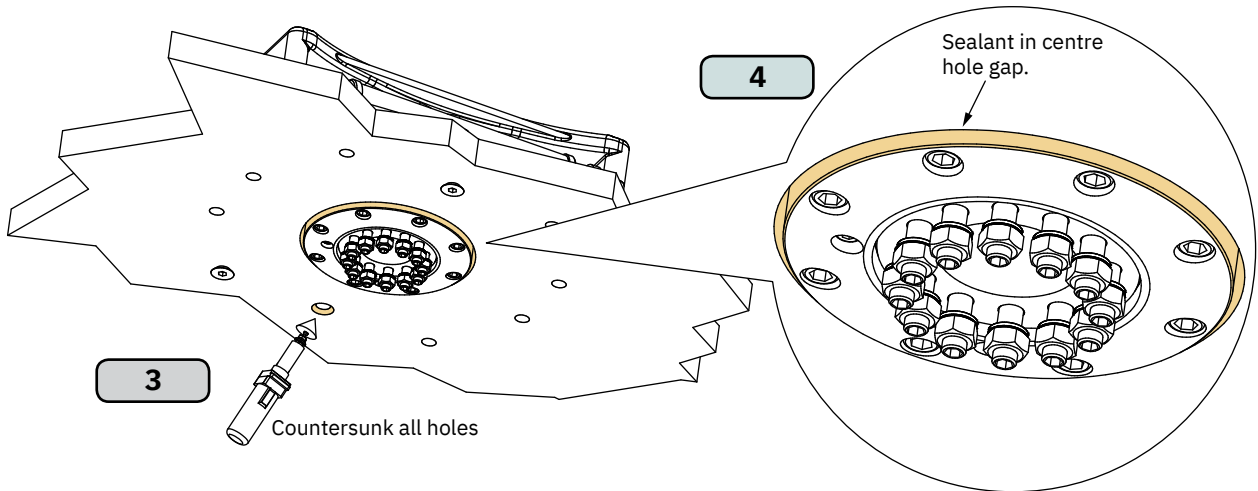

MG_0219

! Please refer to the graphic for special considerations relating to your model !

MOUNTING OF THE STABILIZER ACTUATOR ASSEMBLY

1. Apply a coat of watertight sealant externally to the hull surface. Ensure to fill around the bolts.
2. Place the External Securing Plate over the Stabilizer shaft & onto the external hull mounting surface.
3. Coat the securing bolts with sealant and insert to the External Securing Plate.
4. Secure each bolt with a plain washer and a nut. Tighten & torque load the securing bolt nuts diagonally to avoid misalignment.

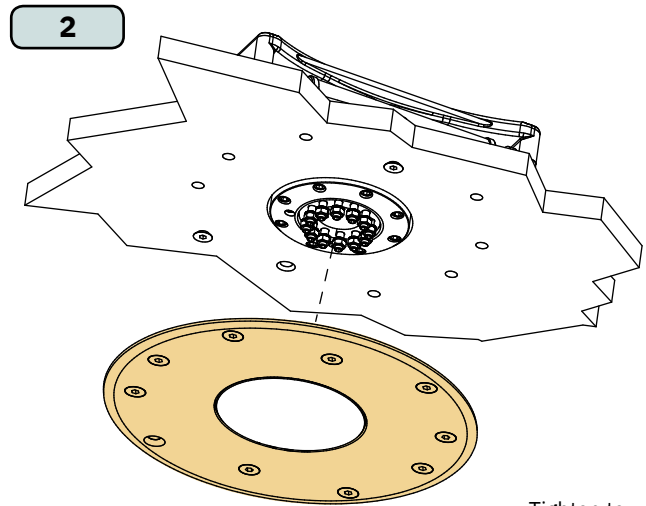
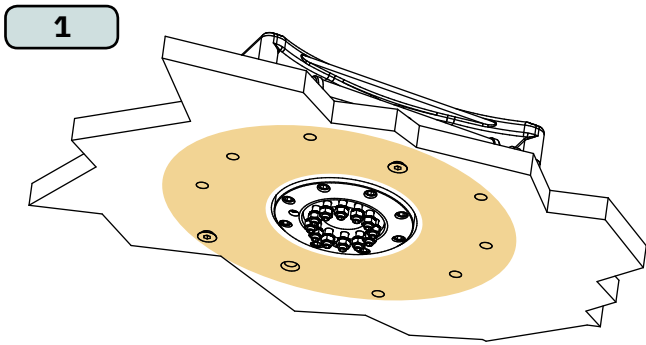

IMPORTANT
Sealant must be compatible with hull and hull plate material. Naval architect/Boat builder must confirm this.

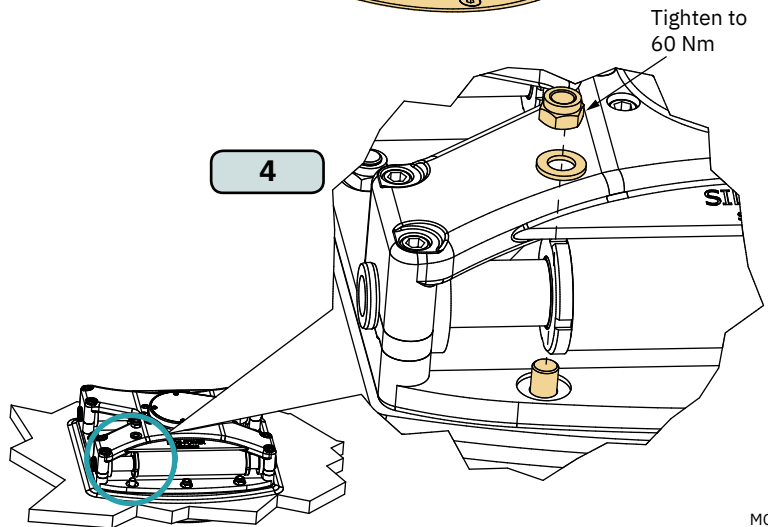
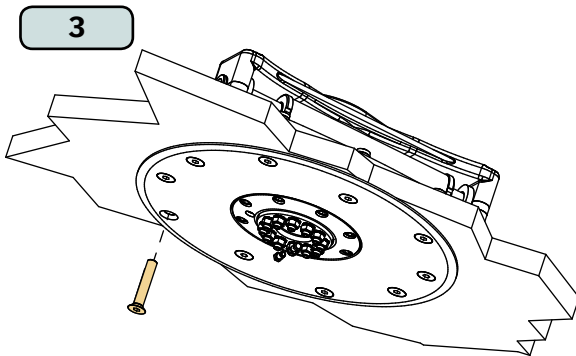

MG_0220

! Please refer to the graphic for special considerations relating to your model !

MOUNTING OF THE STABILIZER ACTUATOR ASSEMBLY

1. Connect a ground wire from the yacht's main bonding/anode system to each actuator using M8 bolt and spring washer in the fixing point.

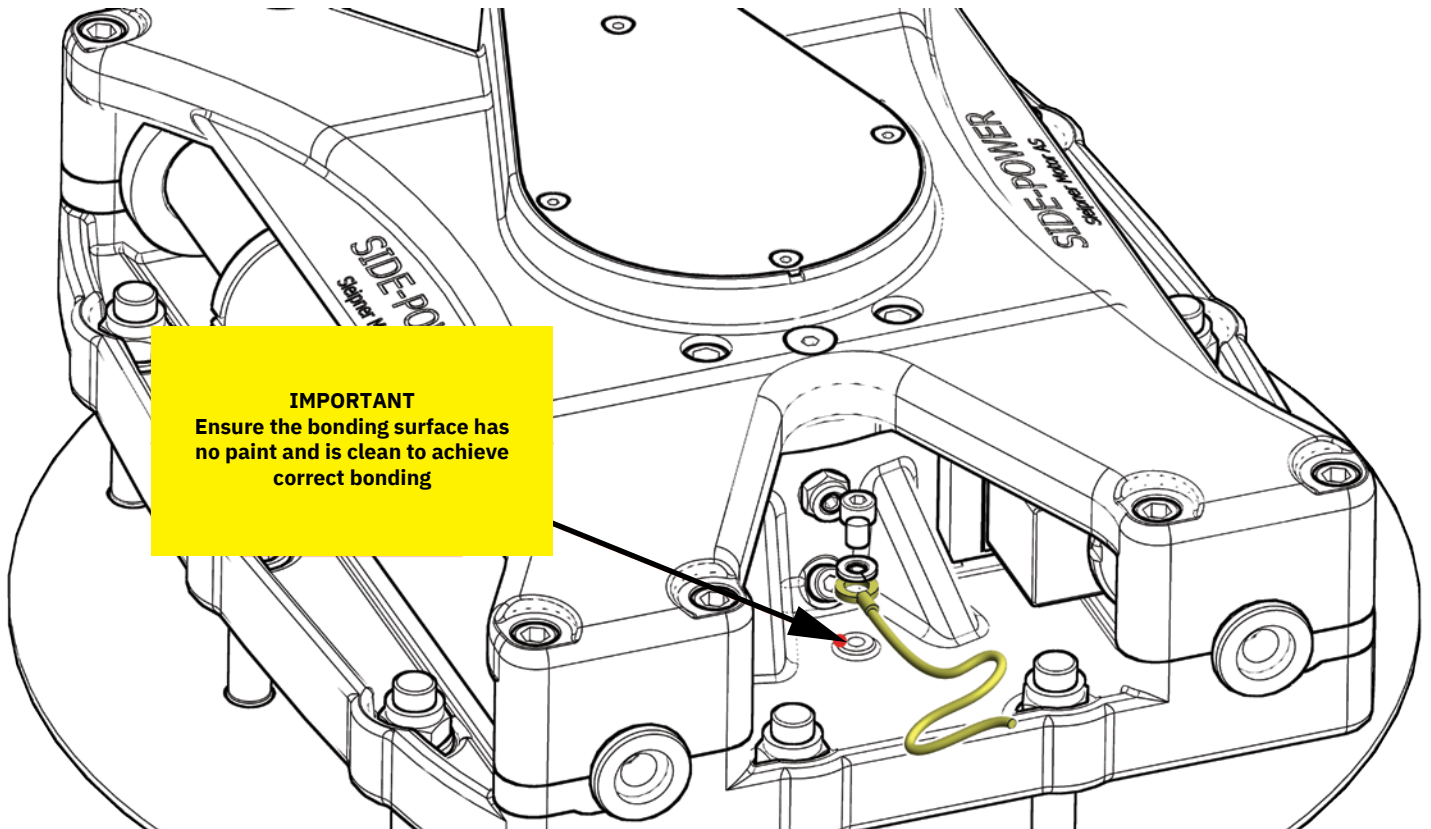

MG_0221

Hydraulic Installation

For specific details see the hydraulic system installation, Start-up, User & Service Manual. Actual system drawings and diagrams will follow the product and specific system manual on delivery.

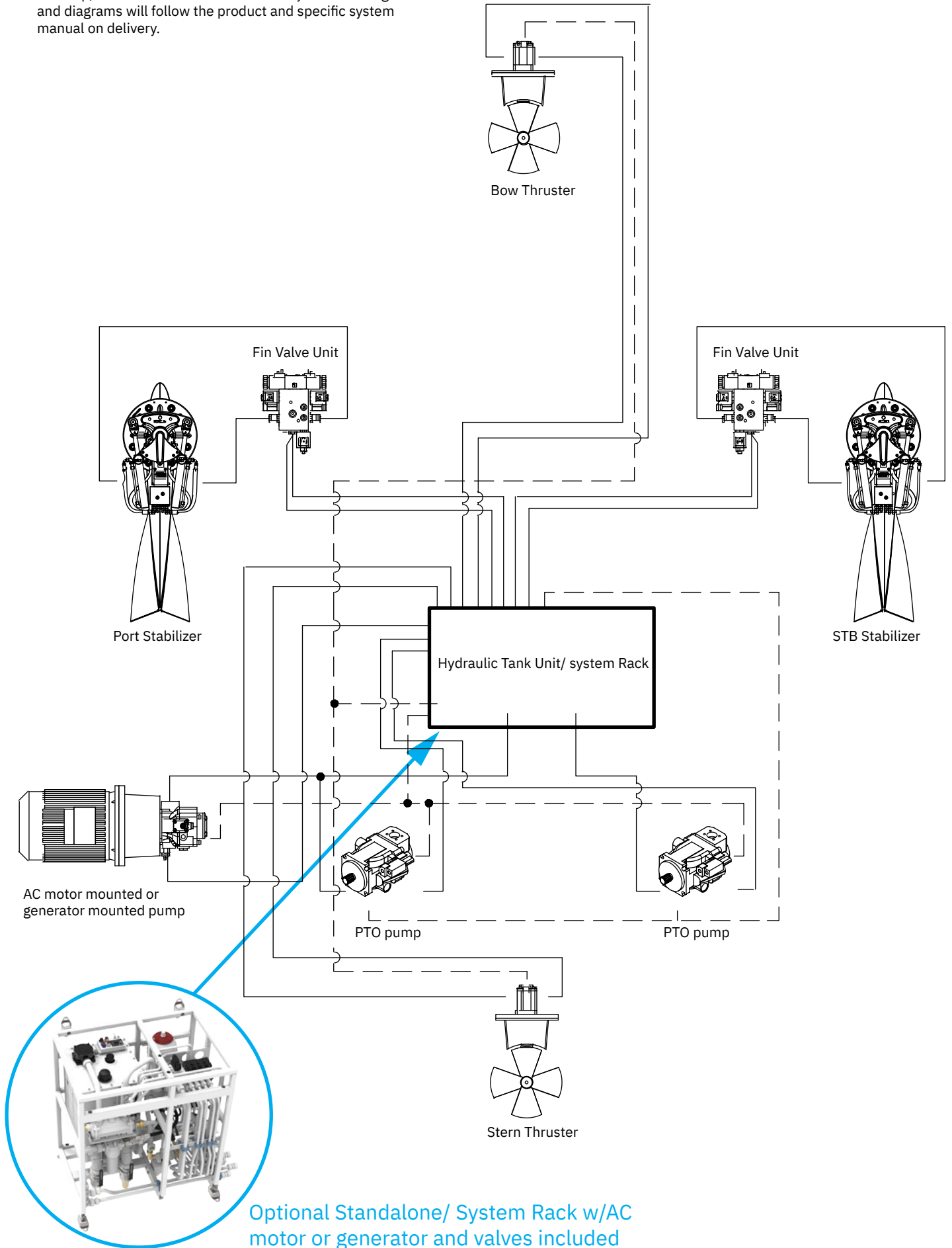

Optional Standalone/ System Rack w/AC motor or generator and valves included

IMPORTANT

For specific and complete details see Side-Power 'Hydraulic System Installation, Start-up, User & Service Manual'. Actual system drawings and diagrams will follow the product and specific system manual on delivery.

Tank Installation

- Place the tank in a position where you have access to connections and inspection points. Ensure that there is enough space to remove and replace the filters. **(NB: Ensure room for access to the oil filling point.)**
- Place the tank high enough to get the oil level above the hydraulic pump. The system requires overpressure/gravity feed in the pump feed lines.
- Secure the tank assembly properly.
- Ground the tank electrically to the boat's bonding system.
- Ensure that the tank and other components are thoroughly clean before you start the installation of fittings and hoses. Also, make sure that the fittings and hoses are thoroughly clean (avoid ingress of dirt, water and other contamination).
- Ensure to plan and install the cooling system in accordance with the Hydraulic system manual.

Pump Installation

- Check that the power source drive direction is in accordance with pump rotation!
- Pump direction is decided as described in Hydraulic system manual, facing the pump shaft, i.e the pump direction will be the opposite of engine / PTO /generator. (NB: Please see (PTO) pump nameplate L=CCW and R=CW)
- Ensure that the power source and connection point can handle the torque and load from the hydraulic pump.
- As soon as the pump is connected to the power source, it is very important NOT to run the power source before the installation is complete and the pump is pre-filled with hydraulic oil.

Hydraulic Hoses

Each thruster system is calculated and correctly set up individually by Sleipner. Please see the unique system drawings in the provided system manual for hose/tube/fittings dimensions. Hoses and fittings must be installed by trained professionals only. Make sure to clean the hoses internally before assembly, all hoses MUST be cleaned with jet pellets or flushed before they are fitted **(NB: Cleanliness requirement according to: Required cleanliness class ISO 4406-1999 21/19/16).**

To ensure easy and trouble-free connection, apply a small amount of oil to threads and mating faces before connecting. Different fittings will require different tightening torque to avoid leakage. If in doubt, please contact a skilled professional to get the best results. It may be required to check and re-tighten all hose connections after start-up and sea trial.

Oil filling

Before filling the tank, prime the pump(s) through their upper drain port. Use only oil quality as specified. Fill the tank with correct hydraulic oil through the filler/breather unit. It is recommended to use a filler trolley with filter (10 micron). Use only new mineral based hydraulic oil, ISO VG46. Use ISO VG32 oil on systems without stabilizers when the vessel will operate in arctic conditions.

Oil to be according to ISO 11158 Class HV/DIN 51524 Part 3 Class HVLP. The oil level in the tank should be approximately 3/4 full, or at the middle of the upper indicator of the sight glass. Because vessels heel and the fact that we have an air breathing filter in the oil filler cap, avoid higher oil level than what the sight glass can indicate. Always check oil level and refill during start-up and air purging.

PTO pump pre-startup

IMPORTANT

Before filling the system oil tank, prime the pump(s) through their upper drain port. Stabilizer system must not be activated. Check pump feed line from the tank (Dimension/routing) for good gravity feed.

- Fill the hydraulic tank. (ISO VG 46 (by ISO 3448). Or, 32 for Arctic climate.) See detailed specifications.
- Remove the pump drain blank or hose from pump to ensure the oil has reached pump)
- Re-fit drain blank or hose in PTO pump port, or at the gauge on accumulator block.
- PTO1: Start engine1 and watch pressure gauge for standby pressure of 10-30 bar. (Monitor oil level)

(NB: Gauge at PVG valves for thruster + stabilizer system. For stabilizer only pressure reading on system status page in the stabilizer control panel.)

- PTO2: Start engine2 and watch pressure gauge for standby pressure of 10-30 bar. (Monitor oil level)

(NB: If no pressure, confirm pump rotation.)

- Check for leaks between tank and pump that is running
- Shut down engine(s) and check the oil level in the tank. Refill if required. (Refill oil only after the accumulator tank is de-pressurized to avoid flooding the tank later on.)

PTO pump pressure adjustment

Most stabilizer systems come with pre-set PTO-pump(s) from Sleipner. The pump has a tag on the drive shaft telling actual pressure setting if this tag is not present, or other settings are required the pump pressure must be checked and adjusted if necessary.

(NB: System pressure will always be directly related to the actual system load at the time. Lack of system pressure is more often caused by open bleed/bypass/dump valve or other system related problems than incorrect pump setting.)

When the above issues are excluded and pump pressure is confirmed incorrect contact Side-Power for pump adjustment instructions. Please have system serial number and pump model data available for correct instructions.

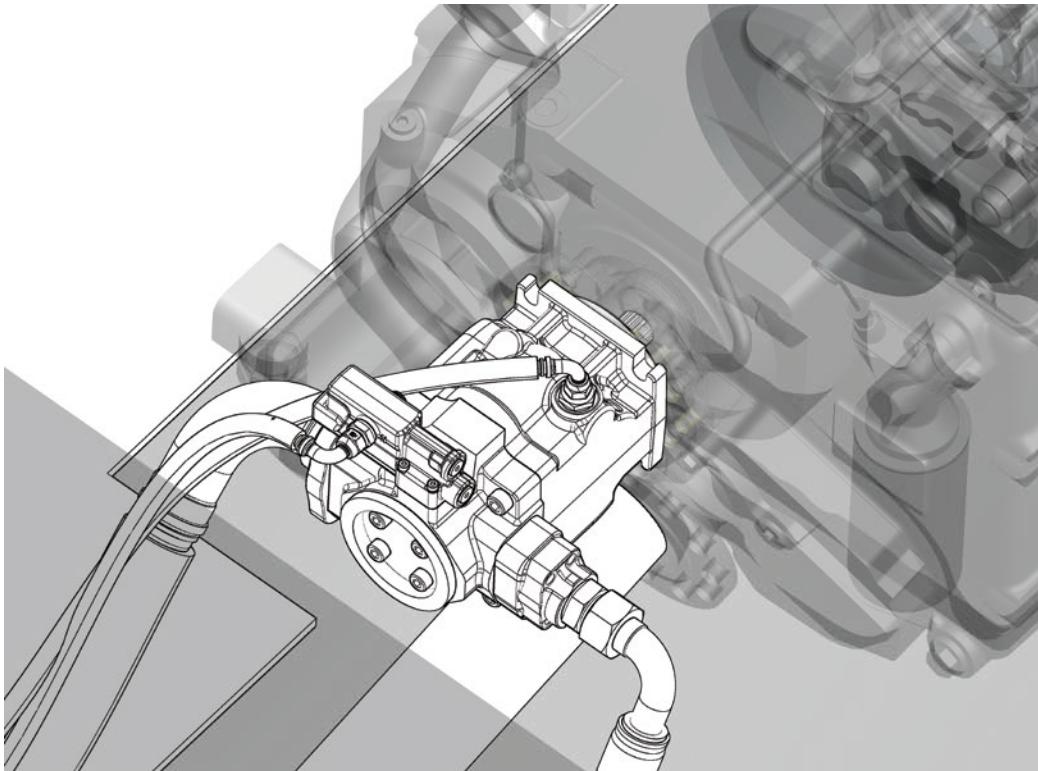

MG_0223

Actuator Valve Unit.

The valve has multiple functions:

1. Combiner for the cylinder hoses
2. Electric operated decouple valve
3. Manual operated decouple valve

Manual operation:

- Push the red button for manual bypass/de-coupling.
- Fins are now free and can be moved manually to the required position.

Hose Connection

Some banjo fitting brands used in combination with metric or BSP crimp fittings can cause interference between the swivel nut and the cylinder rod end. If required, the electrical operated decouple valve coil/solenoid can be removed during hose installation for better access to the hose fittings.

IMPORTANT
Electric operated decouple valve (coil nut) to be re-torqued to 6.8-9.5 Nm (5-7 Ft-lbs) Over torque of the coil nut will damage the valve function.

WARNING
If the valve is unlocked and opened be aware of unexpected movement of fins and cylinders. Especially if the boat is afloat !

Fin Valve Unit

The Fin valve unit should be located as close as possible (Recommended < 2,5m (max 3,5m)), to the Actuator Valve Unit with recommended hose dimensions (System drawings). Use a minimum 2 layer steel braided hoses.

If the fin valve unit is installed more than 2,5m from the actuator, very stiff (none expanding) hoses or even better, some of the distance in rigid piping is necessary to not make the fin movement "soft" by the hoses expanding with varying pressure. Always fit hoses to the hull on soft mounts.

The unit must be mounted on a rigid flat surface - and we recommend to use a vibration dampening material behind them to avoid any high-frequency noise/vibration to go into the structure of the boat.

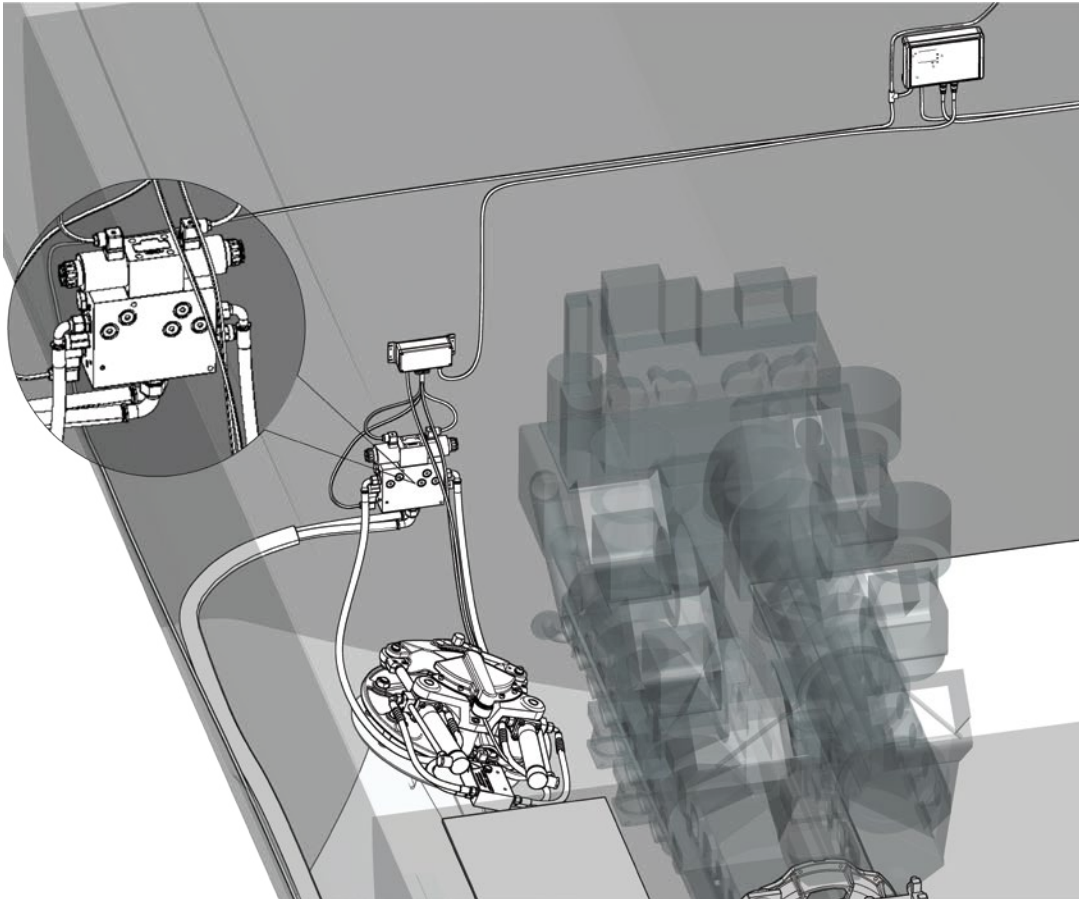

IMPORTANT
The unit must be mounted on a rigid flat surface

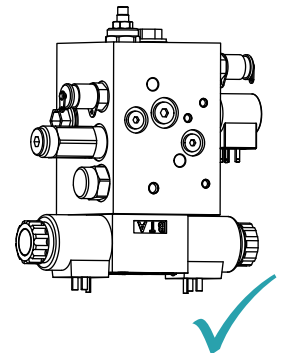
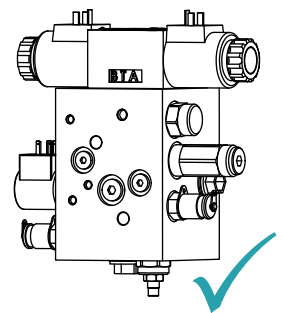

MG_0225

Fin Valve Unit manual decouple operation

The manual operated valve can be used to allow manual movement of the Stabilizer Actuator Rams/Stabilizer fins.

- Unlock valve by turning the 9/16" lock nut anti-clockwise
- Open the valve by turning 3/16" Allen key anti-clockwise.

Fins are now free and can be moved manually to the required position.

IMPORTANT

Manual decouple valves have to be fully closed during normal operation of the stabilizer system.

WARNING

If the valve is unlocked and opened be aware of unexpected movement of fins and cylinders. Especially if the boat is afloat.

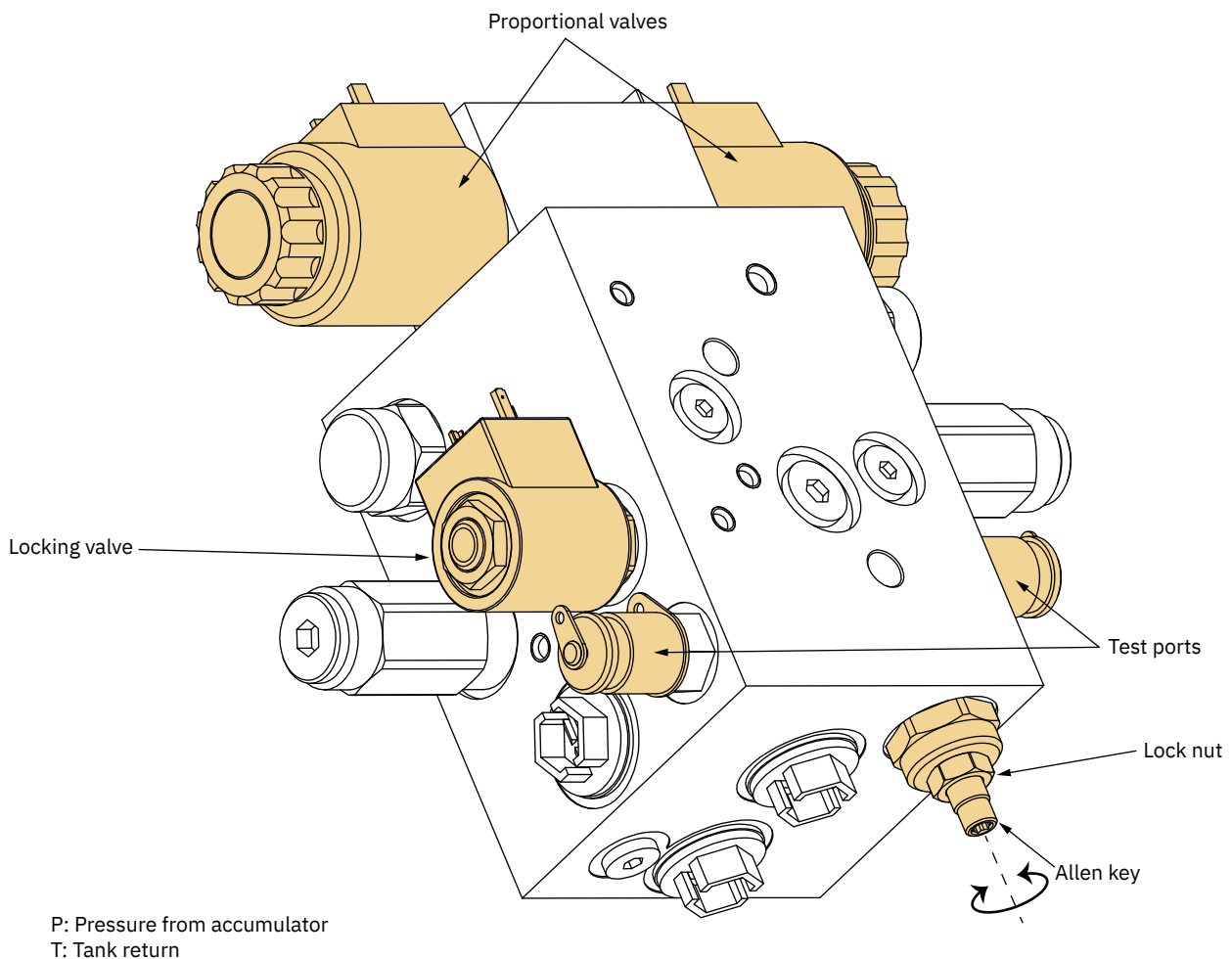

MG_0226

Accumulator tank

All stabilizer systems have accumulator tanks. The main purpose of the accumulator is to create additional capacity and quicker response to the stabilizing system. It also has a pulse dampening effect for the system.

For Nitrogen(N₂) filling and testing procedure - see HYDAC manual. (Accumulator tank supplier) Bladder charge pressure - 45bar.

Base kit (Filling kit) - 321308 covers these countries: Austria, Belgium, Check Republic, Denmark, Finland, Germany, Netherlands, Norway, Poland, Sweden, Switzerland.

For other countries, additional adapters must be used, see HYDAC manual for the correct adapter.

IMPORTANT

Due to logistic reasons most accumulator tanks are shipped without nitrogen(N₂) (if nothing else is agreed when the order was placed) in the pressure bladder in top of the accumulator tank. Therefore, make sure to fill the tank or check the pressure before startup according to the accumulator tank manual.

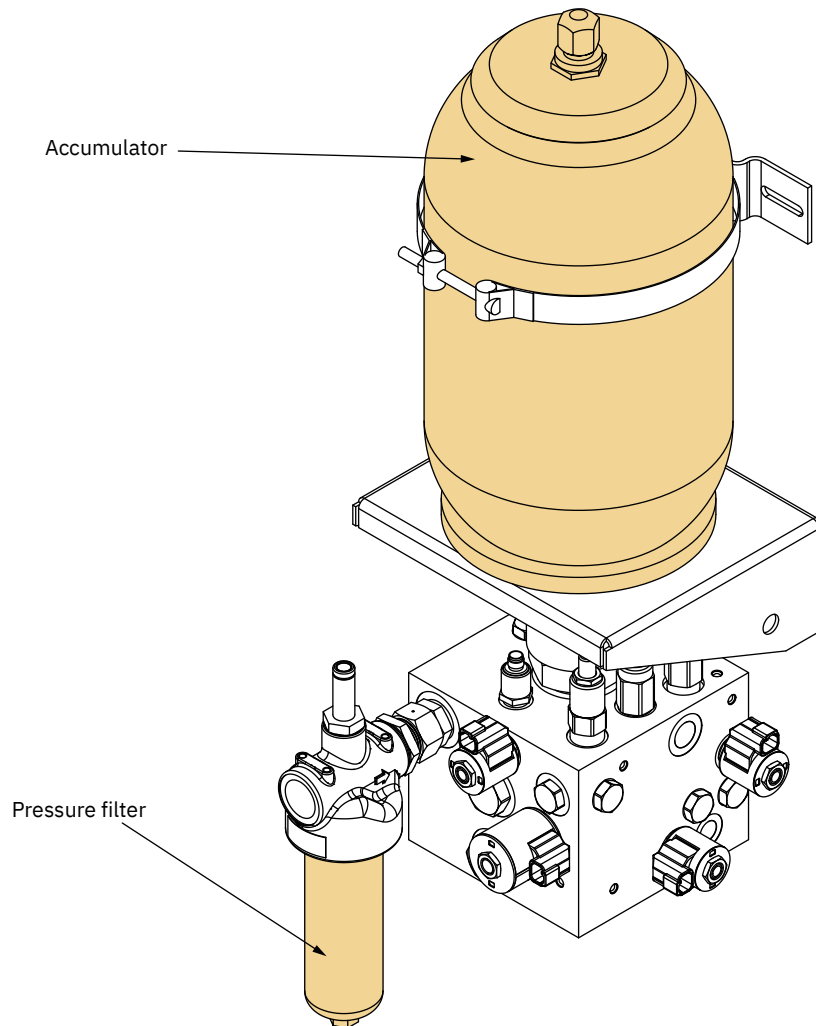

WARNING
Running the system without any nitrogen/pressure on the tank will damage the stabilizer system.

MG_0227

Main Valve Unit

The following functions and ports are integrated into the Main Valve unit:

- (1) - Accumulator Unloading Valve
- (2) - LS-V: Load sense from Tank-mounted valve unit
- (3) - PC: Pressure to Cooling Pump
- (4) - Cooling Pump ON/OFF valve
- (5) - Feed from Main Pump(s) ON/OFF
- (6) - P-AC: Pressure from AC Pump
- (7) - P-MAIN: Pressure from Main Pumps
- (8) - T: Return to Return Combiner
- (9) - LS-P: Load sense to Main Pumps
- (10) - Manual Unloading Valve
- (11) - P-STAB: Pressure to Fin Valve Units

IMPORTANT

During normal operation, the manual unloading valve has to be fully closed (tightened clockwise).

Refer to system drawings for details

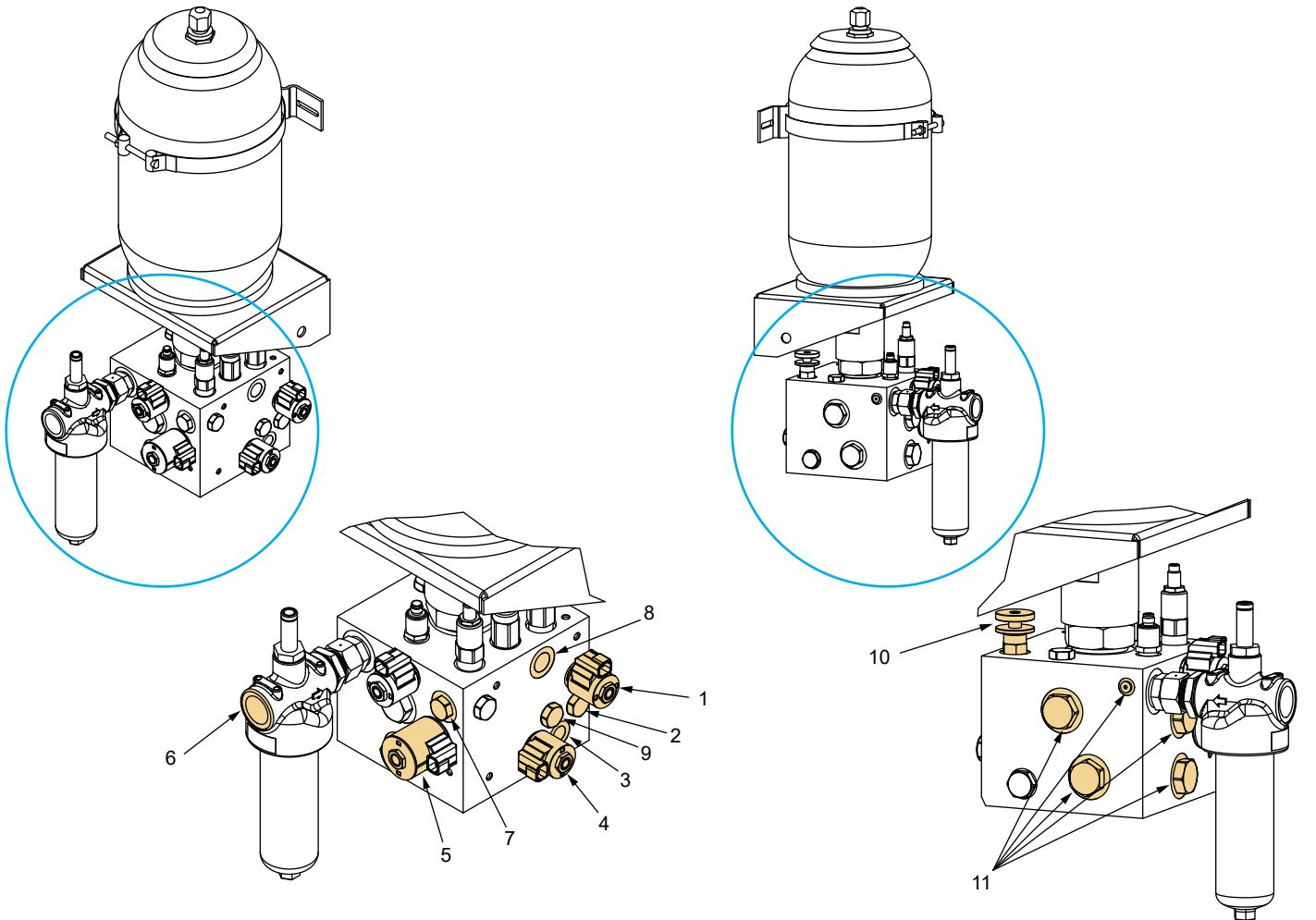

MG_0228

Electrical Installation

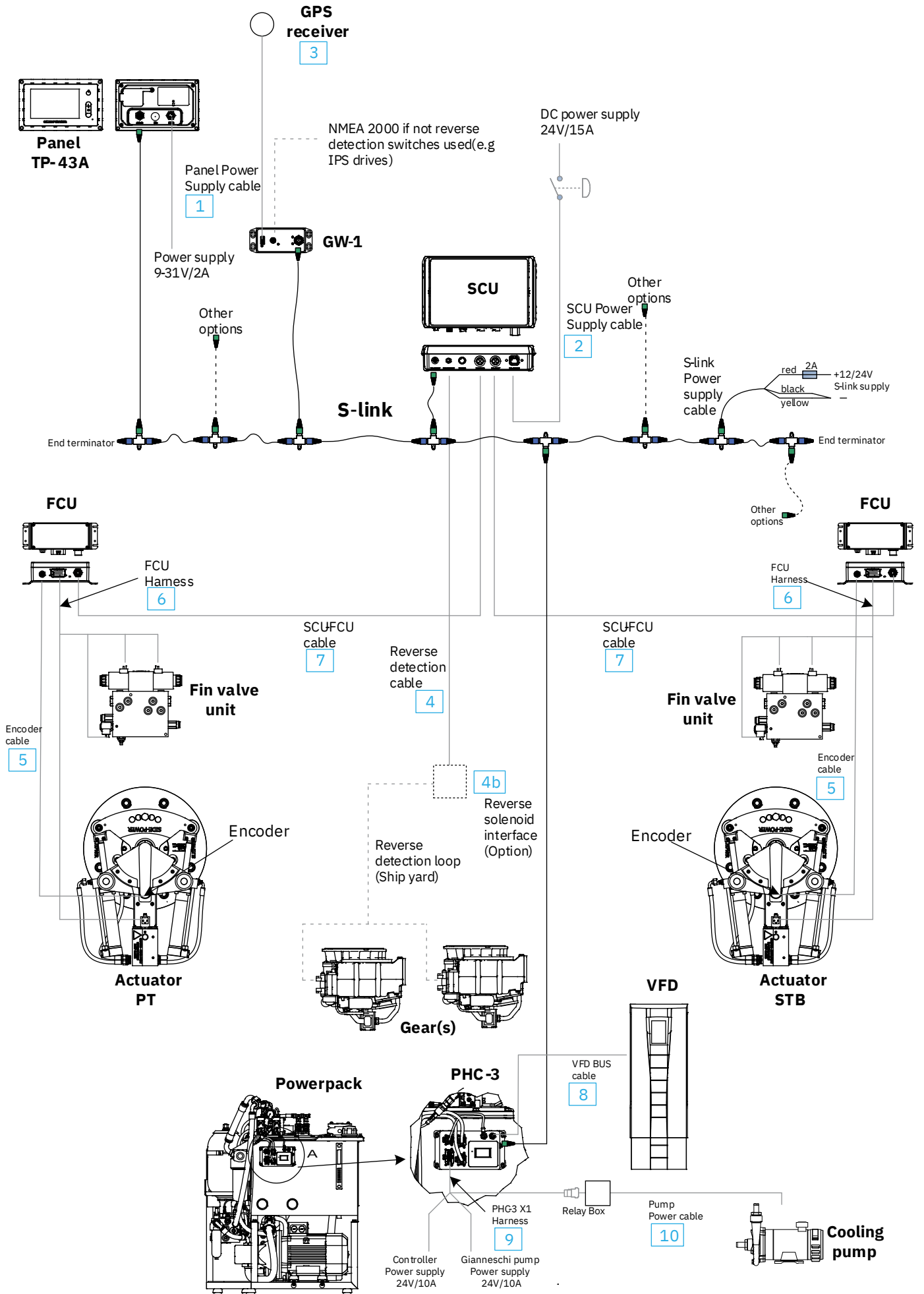

MG_0229

1. Panel Power supply cable Part# 151090-020 - 2m
 2. SCU Power supply cable Part# 151371-025 - 2,5m
 3. GPS Receiver Part# 321714 - 10m
 4. Reverse detection cable Part# 151375-100 - 10m
 - 4b. Reverse Solenoid Interface Part# 151380
- Optionally: pressure switches for ZF or TwinDisc gearboxes.
5. Encoder cable Part# 151271-015 - 1,5m
Encoder cable Part# 151271-030 - 3m
Encoder cable Part#151271-050 - 5 m
 6. FCU harness Part# 151272 - 0,6m+3m
FCU harness Part# 151277 - 5m
 7. SCU-FCU cable Part# 151370-040 - 4m
SCU-FCU cable Part# 151370-070 - 7m
SCU-FCU cable Part# 151370-100 - 10m
SCU-FCU cable Part# 151370-150 - 15m
SCU-FCU cable Part# 151370-200 - 20m
SCU-FCU cable Part# 151370-250 - 25m
SCU-FCU cable Part# 151370-300 - 30m
 8. VFD BUS cable Part# 160311-050 - 5m
 9. PHC-3 X1 Harness Part# 151470-1
 10. Pump power cable Part# 10 2371 (24v) *PHC-3 controls relay inside.
Pump power cable Part# 10 2357 (hyd) * is operated via valve controlled by PHC-3.

IMPORTANT

If installing S-link products DO NOT connect any other control equipment to the S-link controlled products except Slepner original S-link products or via a Slepner supplied interface product made for interfacing with other controls. Any attempt to directly control or at all connect into the S-link control system without the designated and approved interface will render all warranties and responsibilities for the complete line of Slepner products connected void and null. If you are interfacing by agreement with Slepner and through a designated Slepner supplied interface, you are still required to also install at least one original Slepner control panel to enable efficient troubleshooting if necessary.

Mounting the SCU:

Mount the SCU on a bulkhead perpendicular to the keel, as central as possible in the boat (so it moves as little as possible). A typical location is the forward or aftward engine room bulkhead. It must be installed with the cable outlet facing DOWN - the direction if it is mounted facing forward or aft, a setting stating the direction is done in the control panel during setup.

IMPORTANT
The mounting area **MUST** be vibration free.

Mounting the FCU:

Mount the FCU close to the actuator and fin valve unit.

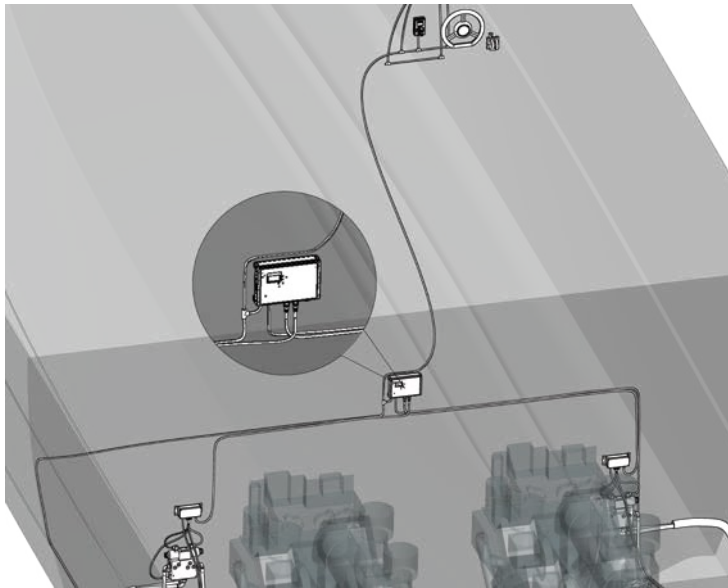

Mounting the SCU

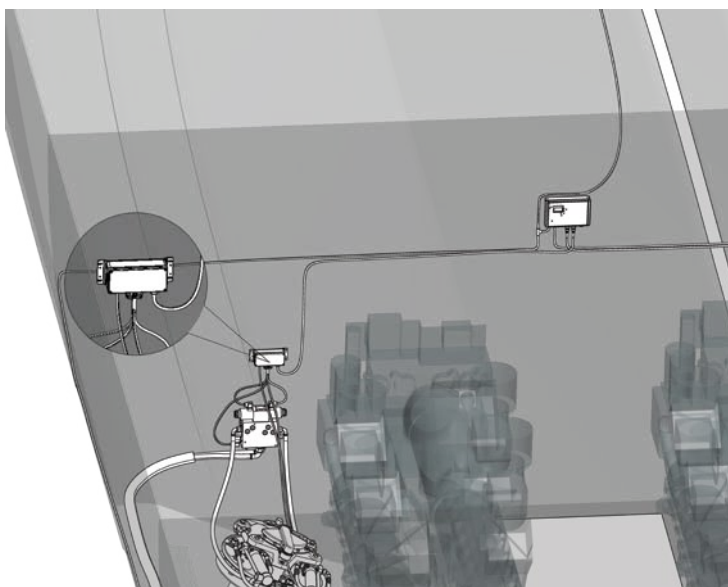

Mounting the FCU

Mounting the Control Panel:

The main operating panel can be fitted on the dashboard(s) from the front using four screws with a smooth plastic cover. Or, it can be “flush mounted” by rear-fitting using studs or other solutions. The Stabilizer operating panel is a 4,3” sunlight-readable touch panel, that is used for setup and operation of the stabilizer system as well as other parts of the S-link system.

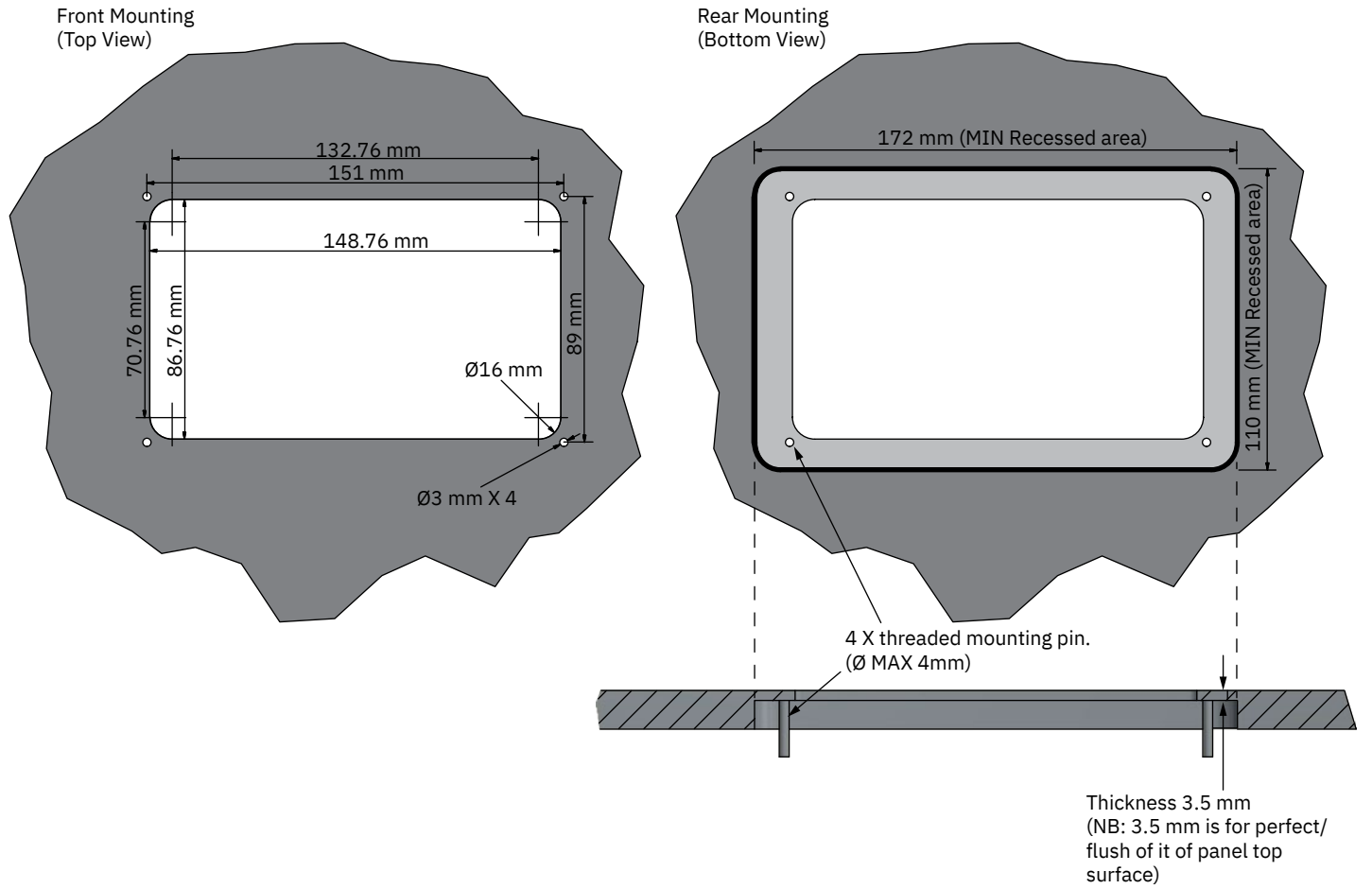

Gasket between the dashboard and back surface of the panel.

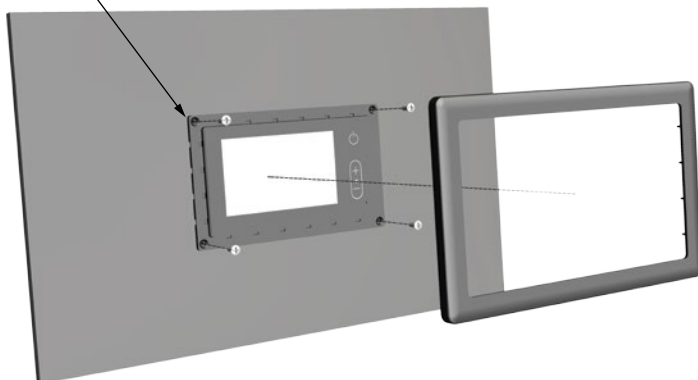

Studs

Gasket

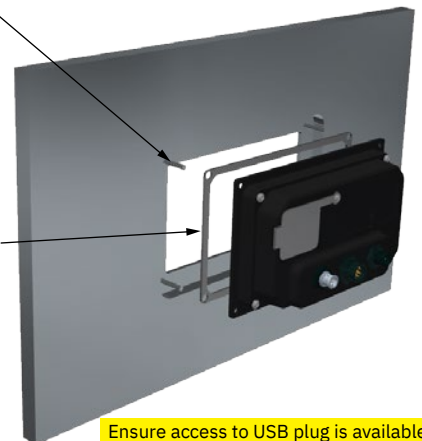

Ensure access to USB plug is available. If necessary use the included USB external plug with cable to extend the USB port. **(NB: This must only be used for upgrading the panel, not as power supply to other USB devices.)**

Mounting the GW-1 including GPS receiver:

Mount the GW-1 within 10m from the GPS receiver, for example under the dashboard. See GW-1 manual for detailed information.

(NB: Ensure to install all electrical connections in appropriate methods to avoid water ingress.)

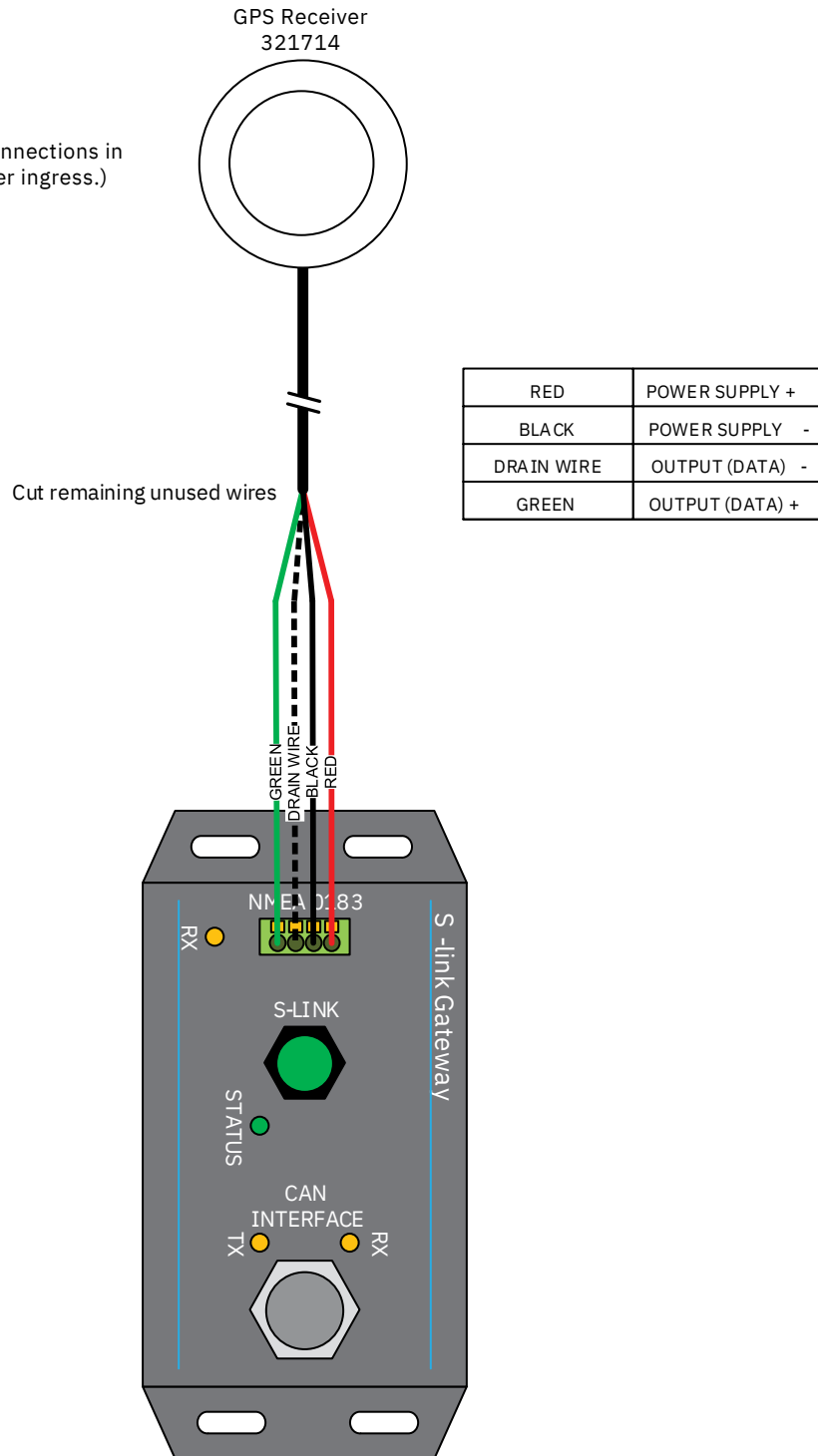

MG_0232

Wiring the control system:

See the electrical wiring diagram supplied with the system.

Control panel:

Connect the supplied power cable to a 9-31V, 2A fused circuit.

Connect the panel to the S-link bus with the appropriate S-link cables.

SCU:

Connect the SCU power supply cable 151371 to a 15A fused 24V DC supply. Plug the cable into connector X1. Connect the 151370-xxx cables for each Fin Control Unit (FCU) to the correct inputs X5-STBD and X6-PORT. Lock the connectors by twisting the locking ring clockwise until a click can be felt. Connect an S-link spur between input X2, and the S-link bus. Connect the 151375 Reverse detection cable into X3. Tighten the connector ring clockwise by hand. This connection should not be made in case of reverse detection over NMEA2000/S-link is implemented. All connector inputs are labelled on the SCU.

FCU:

Connect the 151370-xxx cable from the SCU into the appropriate connector. Lock the connector by twisting the locking ring clockwise until a click can be felt. Connect the wire harness 151272 into the rectangular connector. Connect each of the valve connectors to the correct solenoid valve, and secure the connector screw. Note that Proportional Valve A and Proportional Valve B connectors can be swapped. The actuator tuning performed during commissioning will detect and correct the operating direction. Wiring the actuator position encoder: Remove the yellow protective cap on the encoder connector and connect the 151271 cables between encoder and FCU. Tighten the connector rings clockwise by hand.

S-link:

Basics - The system needs a spur drop cable (green) for each S-link unit and a backbone loop through the yacht where you connect all the spur cables included a power feed spur on T-connectors. If you have upgraded to SEP thrusters you will also have the thrusters and their power switches on the S-link. See S-link overview for cabling references.

GW-1/GPS receiver:

The GPS receiver is wired to the Gateway GW-1 NMEA0183 port, according to the diagram supplied with the GPS receiver. The GW-1 is connected to the S-link bus with the appropriate S-link cables. GW-1 and GPS are powered from the S-link bus. GPS data can also be provided from NMEA2000 GPS receivers if GW-1 is connected to an NMEA2000 network. In case GW-1 is connected both to an NMEA2000 network supplying GPS data, and a separate GPS receiver connected to the NMEA0183 port, the GW-1 will automatically switch between the signals.

Wiring the AC Power Pack:

In the case of single-phase supply systems, a Variable Frequency Drive (VFD) is delivered as part of the PowerPack. The VFD is used as an AC motor starter device, that supply 3 phase voltage for the AC motor. A separate breaker is required for the VFD supply. Recommended breaker size and the wire gauges can be found in the VFD quick start guide. Cable from VFD to the motor should be of a screened type, suited for VFD use. For further reference, see Quick Start Guide supplied with the VFD. For main circuit wiring,

Electrical Installation

Harness: #FCU-KIT-15
 #FCU-KIT-30
 Prop valve connectors A/B (X2/ X3)
 FCU-KIT-50

(NB: Connectors A/B can be placed either way. The valves direction will automatically be identified at startup.)

Lock valve connector (X5)

Fin Valve Unit

Actuator Valve Unit

Float Valve connector (X4)

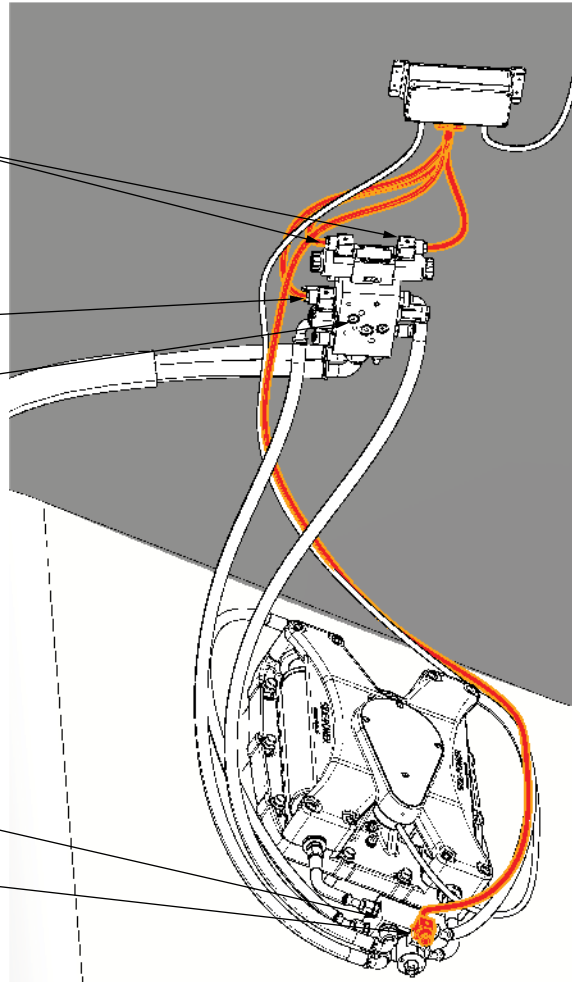

Encoder connection:

Cable: #151271-015
 #151271-030

(Included in FCU-KITxx)

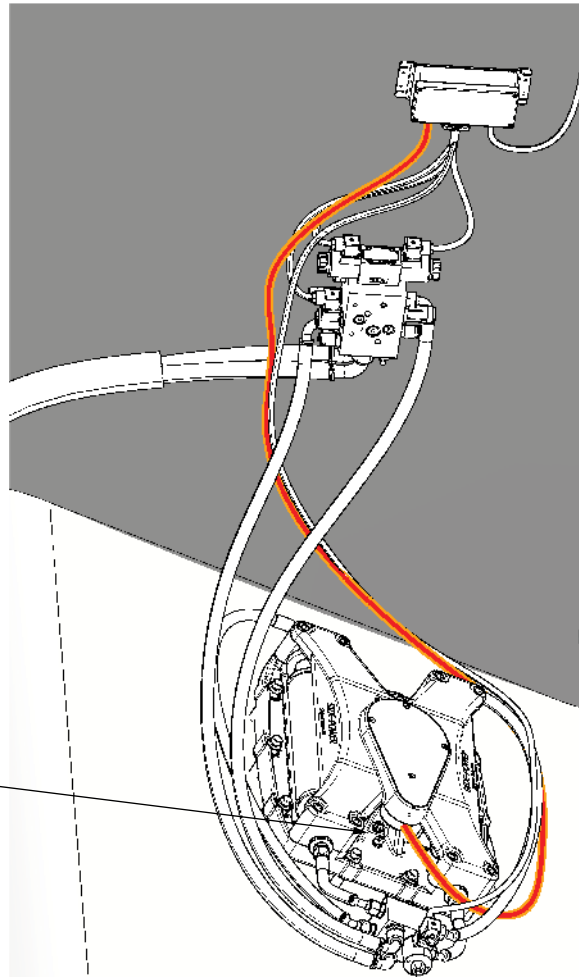

Float Valve connector (X4)

IMPORTANT

All electrical connections and wiring must be secured with cable ties appropriately and not in conflict with actuator cylinder hoses. Do not fasten electrical wires to the hydraulic hoses, as they move when pressure changes.

Electrical Installation

Main Valve Unit:

Harness: #151471-x

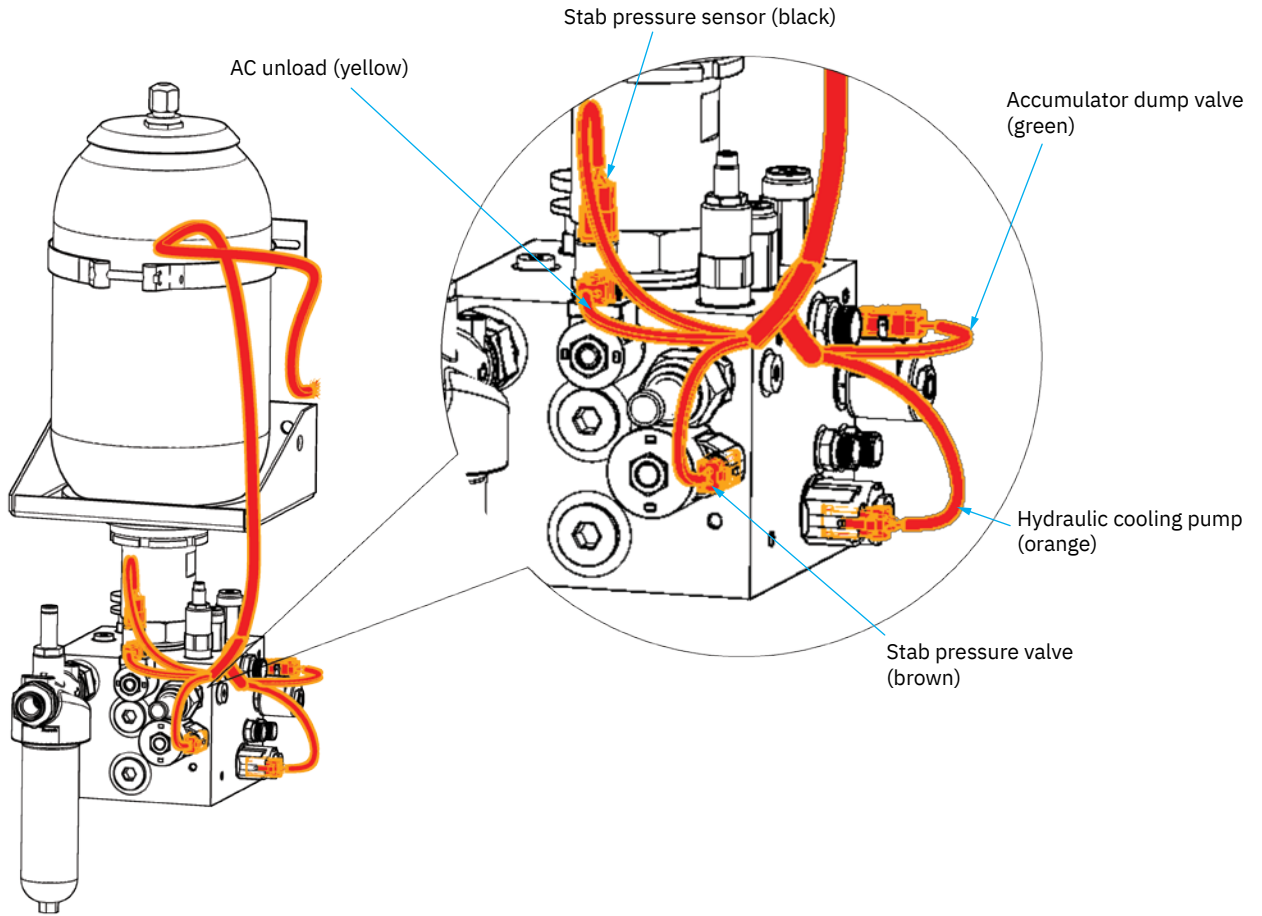

IMPORTANT

All electrical connections and wiring must be secured with cable ties appropriately and not in conflict with actuator cylinder hoses.

Main Valve Unit:

Integrated in a thruster and stabilizer rack. Harness is pre-installed from factory. Also integrated/pre-installed in a standalone stabilizer system.

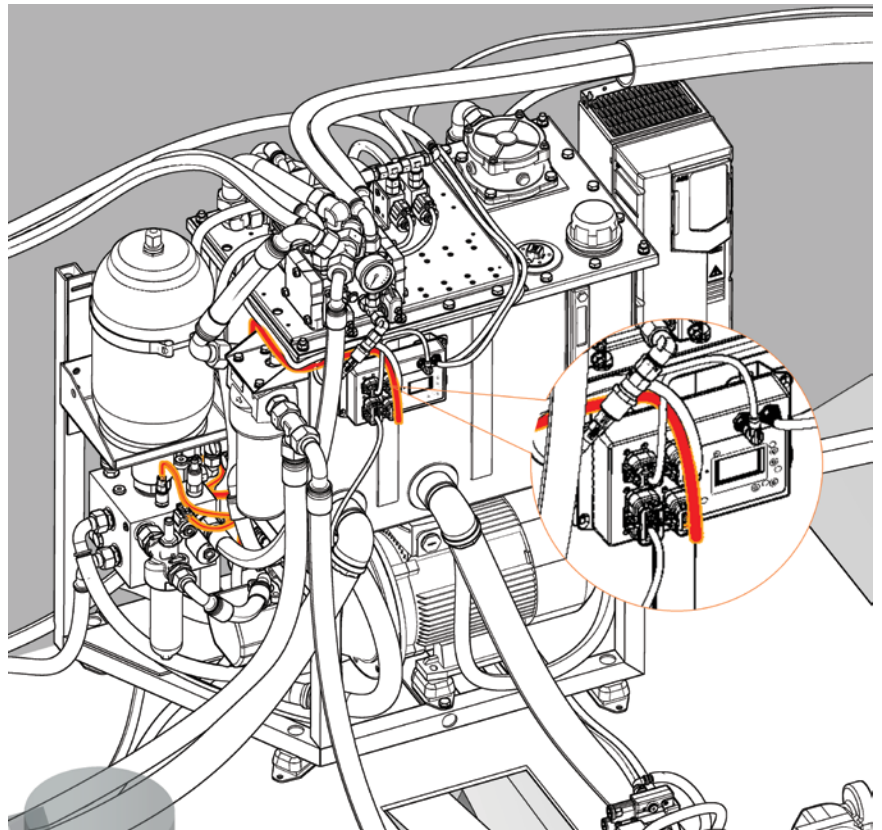

MG_0234

S-Link is a CAN-based control system used for communication between Sleipner products installed on a vessel. The system uses BACKBONE Cables as a common power and communication bus with separate SPUR Cables to each connected unit. Units with low power consumption are powered directly from the S-Link bus therefore one power cable must be connected to the BACKBONE Cable through a T-Connector.

Main advantages of S-Link system:

- Compact and waterproof plugs.
- BACKBONE and SPUR Cables have different colour coding and keying to ensure correct and easy installation. BACKBONE Cables have blue connectors and SPUR Cables have green connectors.
- Different cable lengths and BACKBONE Extenders makes the system scalable and flexible to install.



Installation of S-Link cables:

Select appropriate cables to keep the length of BACKBONE- and SPUR Cables to a minimum. In case of planned installation with total BACKBONE Cable length exceeding 100 meters please consult your local distributor. The S-Link cables should be installed to ensure sharp bend radius's is avoided. Locking mechanism on connectors must be fully closed. To ensure long lifetime, cables, T-Connectors and Extenders should not be located so that they are permanently immersed in water or other fluids. It is also recommended to install cables such that water and condensation do not run along the cables and into the connectors.

The POWER Cable should ideally be connected around the middle of the BACKBONE Cable to ensure an equal voltage drop at each end of the BACKBONE Cable. The yellow and black wire in the POWER Cable shall be connected to GND and the red wire connected to +12VDC or +24VDC.

To reduce the risk of interference, avoid routing the S-Link cables close to equipment such as radio transmitters, antennas or high voltage cables. The backbone must be terminated at each end with the END Terminator.

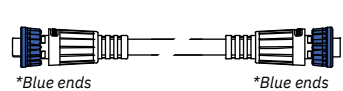
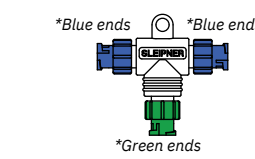
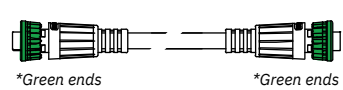
SPUR cables can be left unterminated to prepare for the installation of future additional equipment. In such cases, ensure to protect open connectors from water and moisture to avoid corrosion in the connectors.

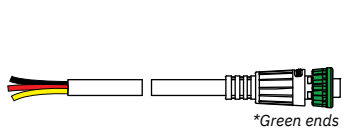
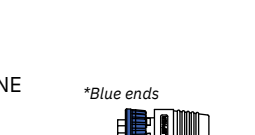
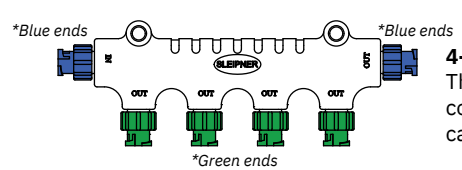
 <p>*Blue ends</p>	<p>BACKBONE Cable Forms the communication and power bus throughout a vessel. Available in different standard lengths.</p>	 <p>*Blue ends</p> <p>*Green ends</p>	<p>T-Connector Used for connection of SPUR or POWER Cable to the BACKBONE Cable. One T-Connector for each connected cable.</p>	
 <p>*Green ends</p>	<p>SPUR Cable Used to connect S-Link compliant products to the backbone cable. One SPUR Cable must be used for each connected component, with no exceptions. Recommended to be as short as practically possible. Available in different standard lengths.</p>	 <p>*Blue ends</p>	<p>BACKBONE Extender Connects two BACKBONE Cables to extend the length.</p>	
 <p>*Green ends</p>	<p>POWER Cable Required in all installations for connection of BACKBONE Cable to a power supply. It shall not be more than one POWER Cable in an installation.</p>	 <p>*Blue ends</p>	<p>END Terminator Must be one at each end of the BACKBONE bus.</p>	
 <p>*Blue ends</p> <p>*Green ends</p>				<p>4-Port T-Connector The 4-PORT T-connector allows multiple SPUR Cables to be connected. The 4-PORT T-connector comes with two sealing caps to protect unused ports.</p>

S-Link installation example

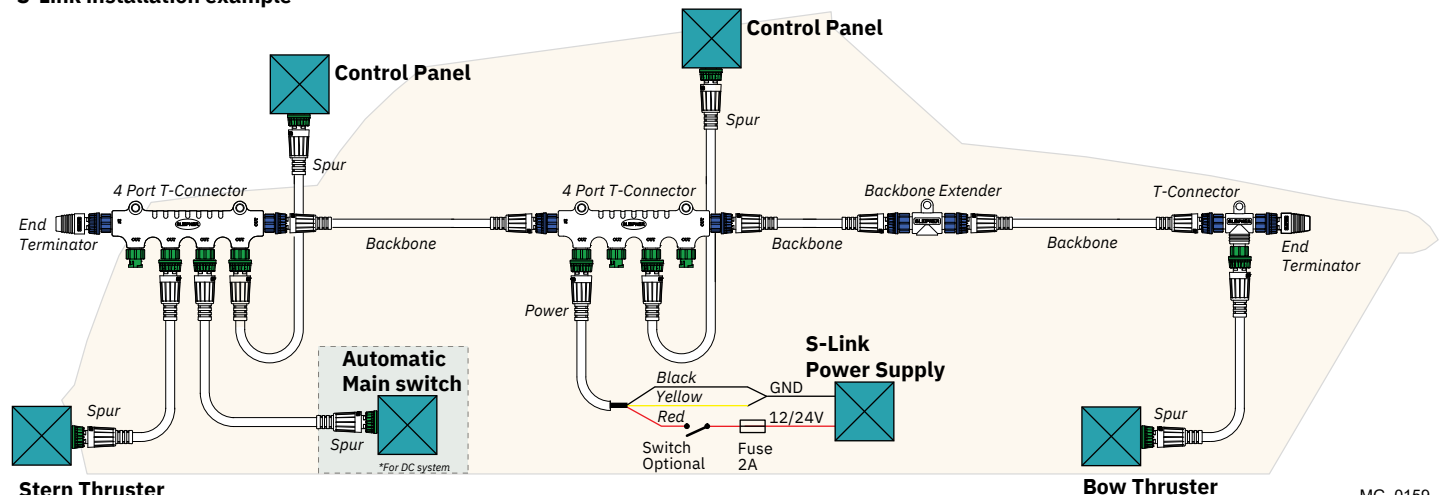

Electrical Installation

Example of S-Link wiring with Stabilizers and DC PRO Thrusters.

You need:

- 2 x 6 1327 End terminators
- 11 x 6 1326 T-connectors
- 1 x 6 1328 Power spur
- 8 x 6 1320-xxM Backbone cables
- 10 x 6 1321-xxM Spur cables
- Recommended Panel: PJC221/222

(NB: Each Panel/S-link unit must have its own T-connector and spur cable.)

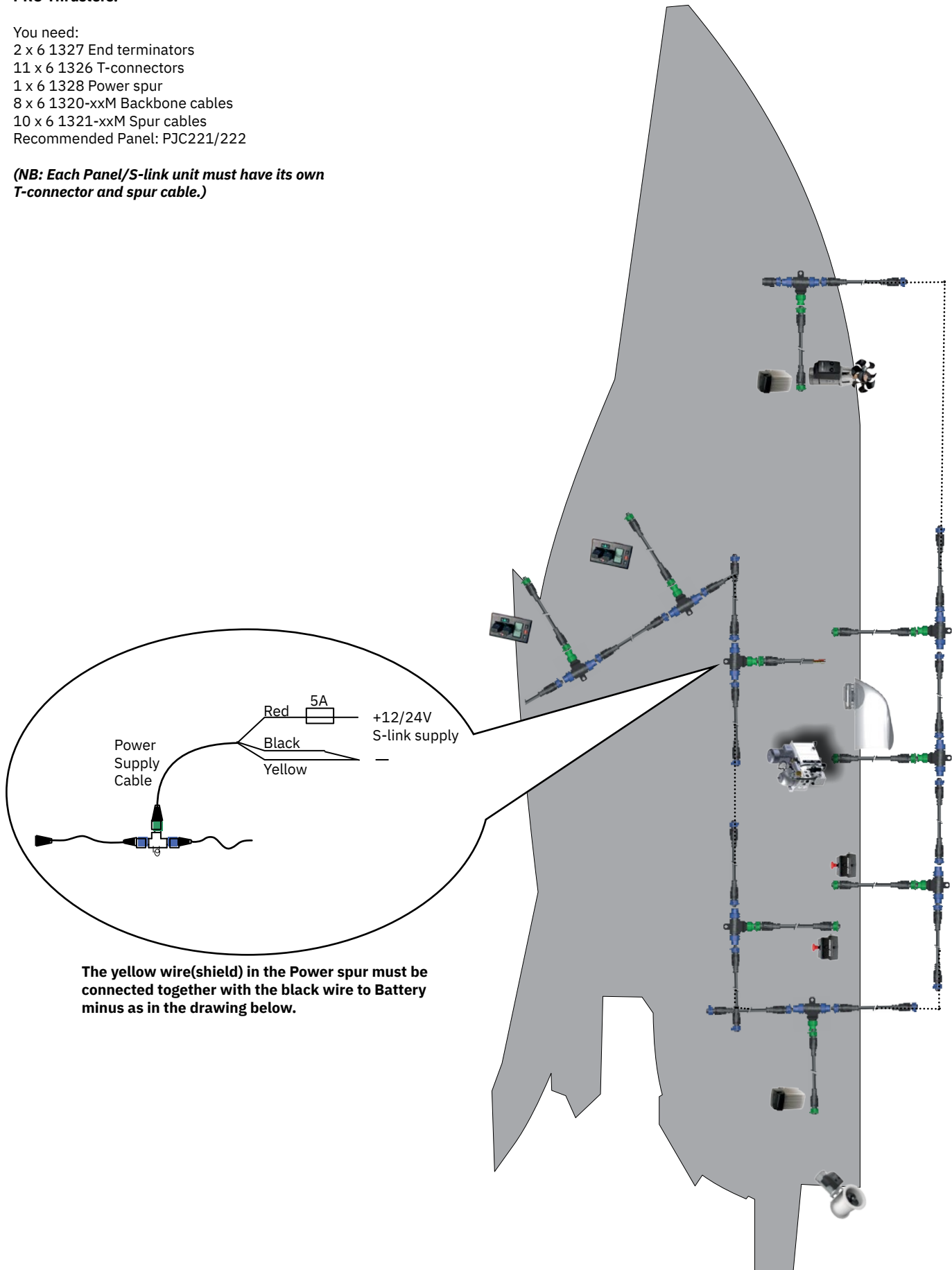

The yellow wire(shield) in the Power spur must be connected together with the black wire to Battery minus as in the drawing below.

Example of S-Link wiring with Stabilizers and HYD Thrusters.

You need:

- 2 x 6 1327 End terminators
- 7 x 6 1326 T-connectors
- 1 x 6 1328 Power spur
- 4 x 6 1320-xxM Backbone cables
- 6 x 6 1321-xxM Spur cables
- Recommended Panel: PJC221/222

(NB: Each Panel/S-link unit must have its own T-connector and spur cable.)

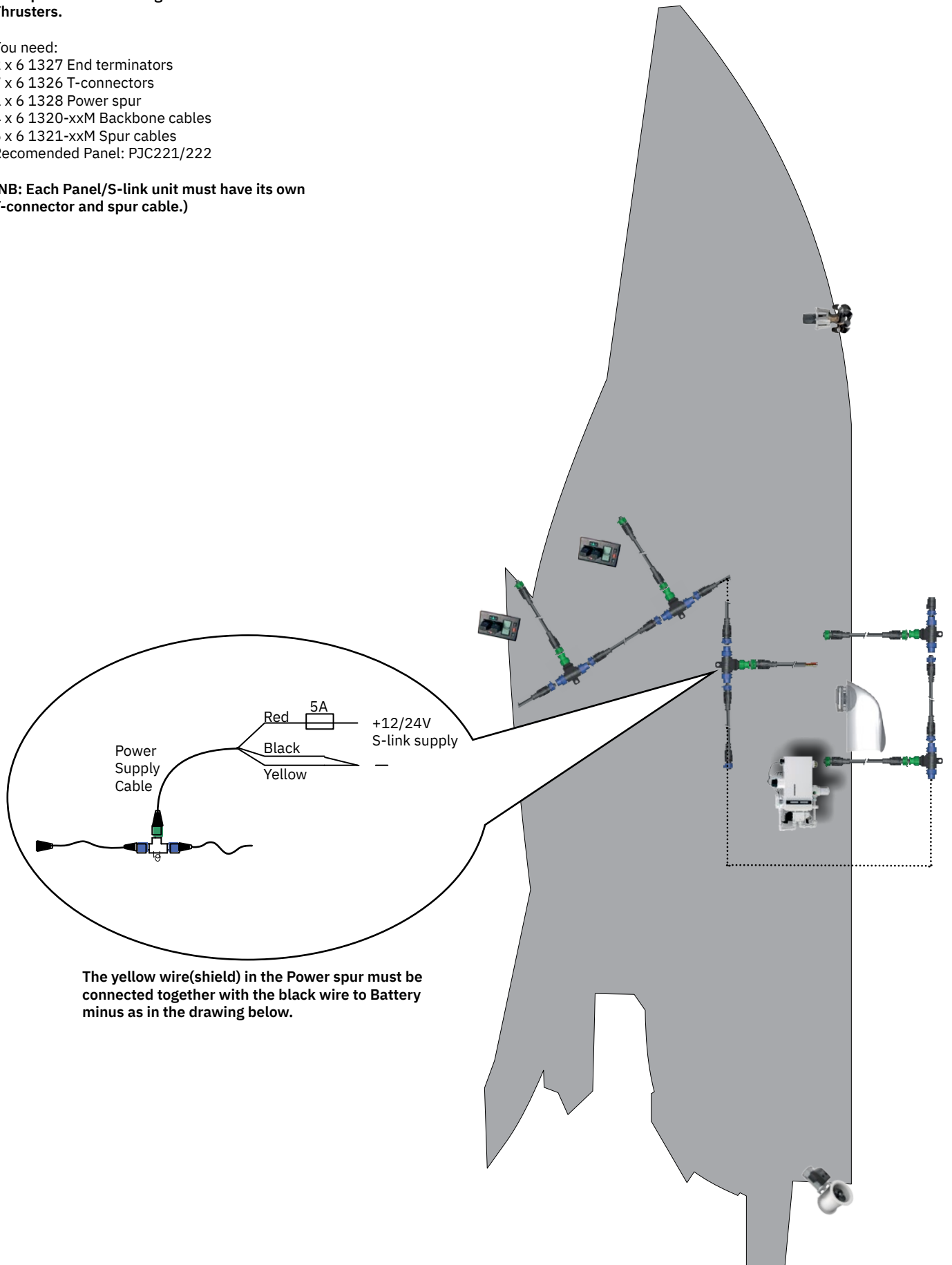

The yellow wire(shield) in the Power spur must be connected together with the black wire to Battery minus as in the drawing below.

VFD:

Mount the VFD relatively close to the PHC-3 controller(Power pack/Rack/Tank/AC motor), within 4 meters.
Harness: #160311-050

(NB: VFD must be protected from any water spray.)

IMPORTANT

Follow the installation guidelines from the VFD manual supplied with the system.

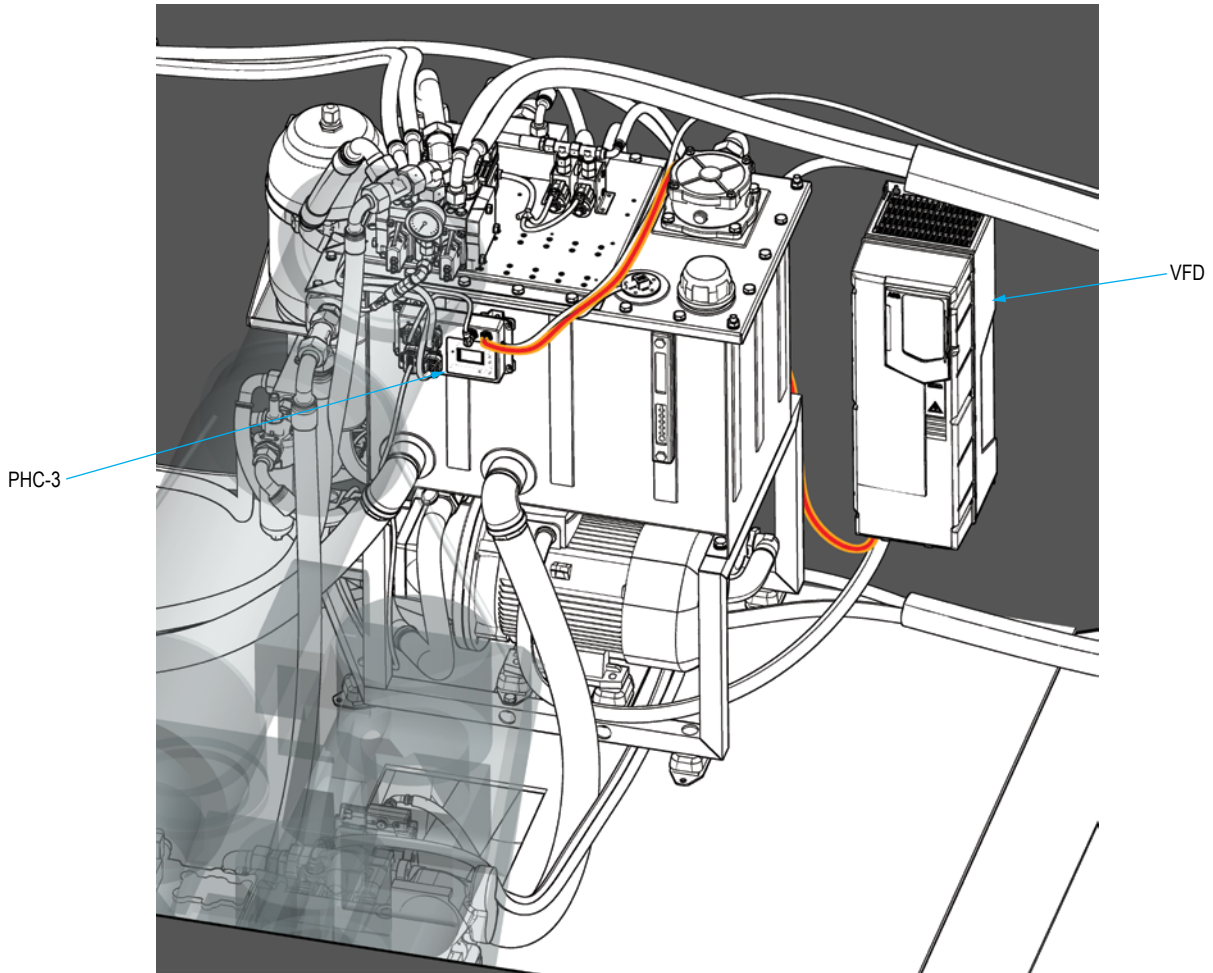

MG_0237

VFD cable dimensions:

* Based on MAX 20 meters cable lengths.

Motor power (kW)	Input Phases	Input Voltage (V)	Input Supply Current (A)	Motor Current (A)	Input Wire Size (mm ²)*	Motor Wire Size (mm ²)*
3,5	1	220	21,8	12,6	4	2,5
4,6	1	220	29,1	16,8	6	4
5,5	1	220	39,0	22,5	10	6
7,5	1	220	46,2	26,7	16	10
7,5	3	220	26,7	26,7	10	10
11	1	220	67,5	39,0	25	16
11	3	220	39,0	39,0	16	16
11	3	400	21,0	21,0	4	4
15	1	220	88,3	51,0	35	16
15	3	220	51,0	51,0	16	16
15	3	400	28,0	28,0	10	10

Changes or misprints might occur in information given.

IMPORTANT

Responsible electrical technician must consider fitting method, temperature conditions and cable lengths before doing this electrical work. This table is just a general recommendation.

Single Phase Supply

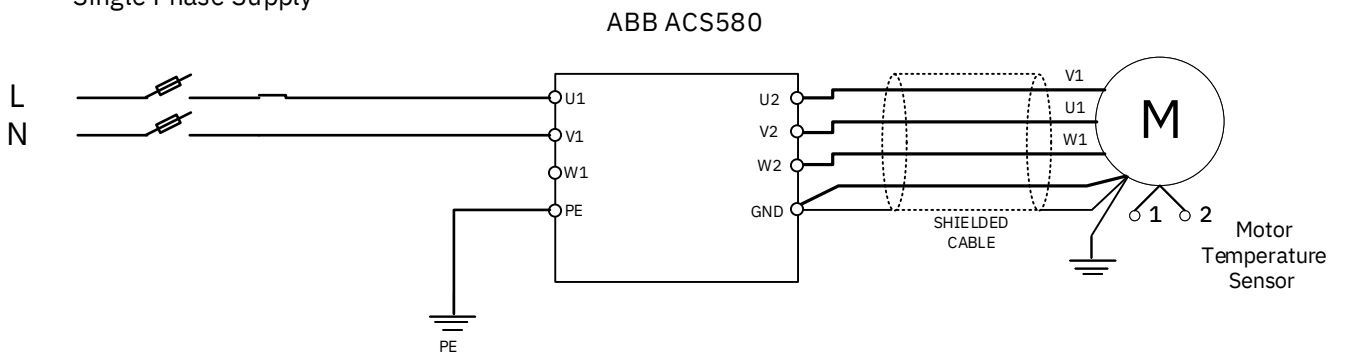

Three Phase Supply

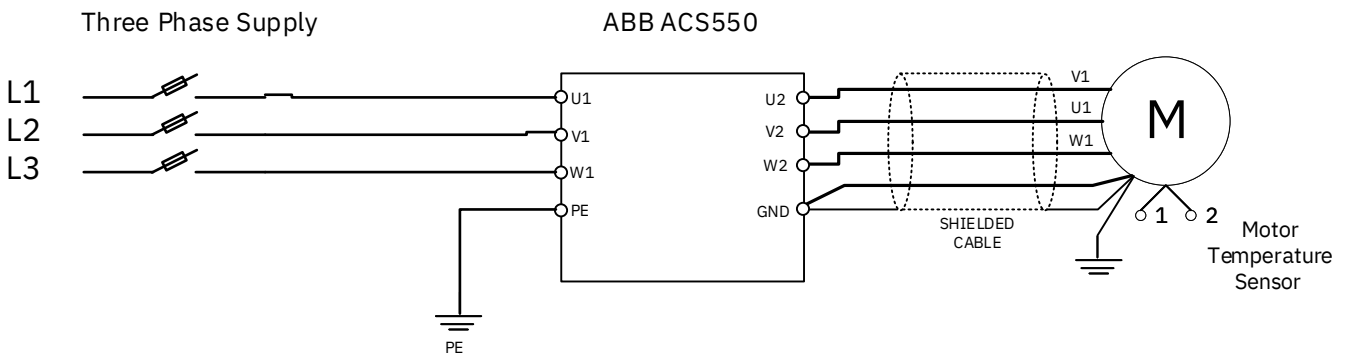

AC Motor driven Pump Unit Pre-Startup

IMPORTANT

The yacht's main engine(s) must be switched off during this procedure. The first start of the AC Motor/Pump Unit must be carried out manually from the PHC-3 control panel. However, before performing pre-startup procedure from the PHC-3 ensure the VFD(variable frequency drive) is in REMOTE mode. The VFD panel is factory programmed, therefore no additional functional programming should be required.

Complete the checklist found at the back of this manual before pressurizing the system!

- Leave Stabilizer system off at control panel. (Bypass and dump valves will be open)
- Check oil level in tank and open cock valves (if present) on AC pump feed line.
- Open the Manual Unloading Valve by turning the wheel fully anti-clockwise.
- AC motor pre-startup from PHC-3: See MANUAL OPERATION – See ABB MANUAL for first start details - START VFD procedure in PHC-3 manual.
- Monitor oil level and stop the AC pump and refill oil if required.
- When pre-startup is completed, close the Manual Unloading Valve.
- Check for oil leaks and tighten if required.

IMPORTANT

Verify the drive direction in accordance with the direction arrow label on the AC Motor/Pump Unit. To better see/feel the drive

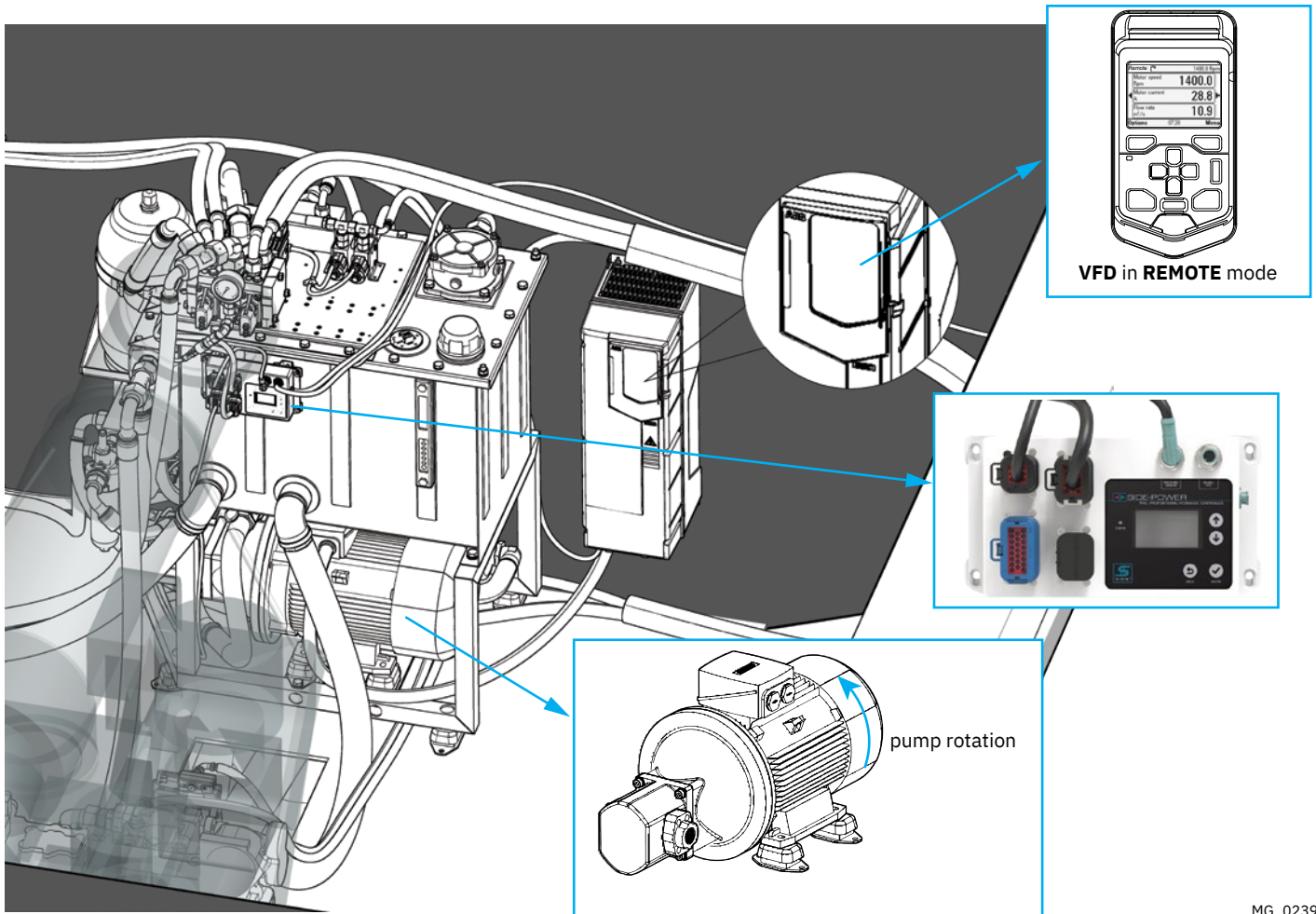

MG_0239

Fin Installation

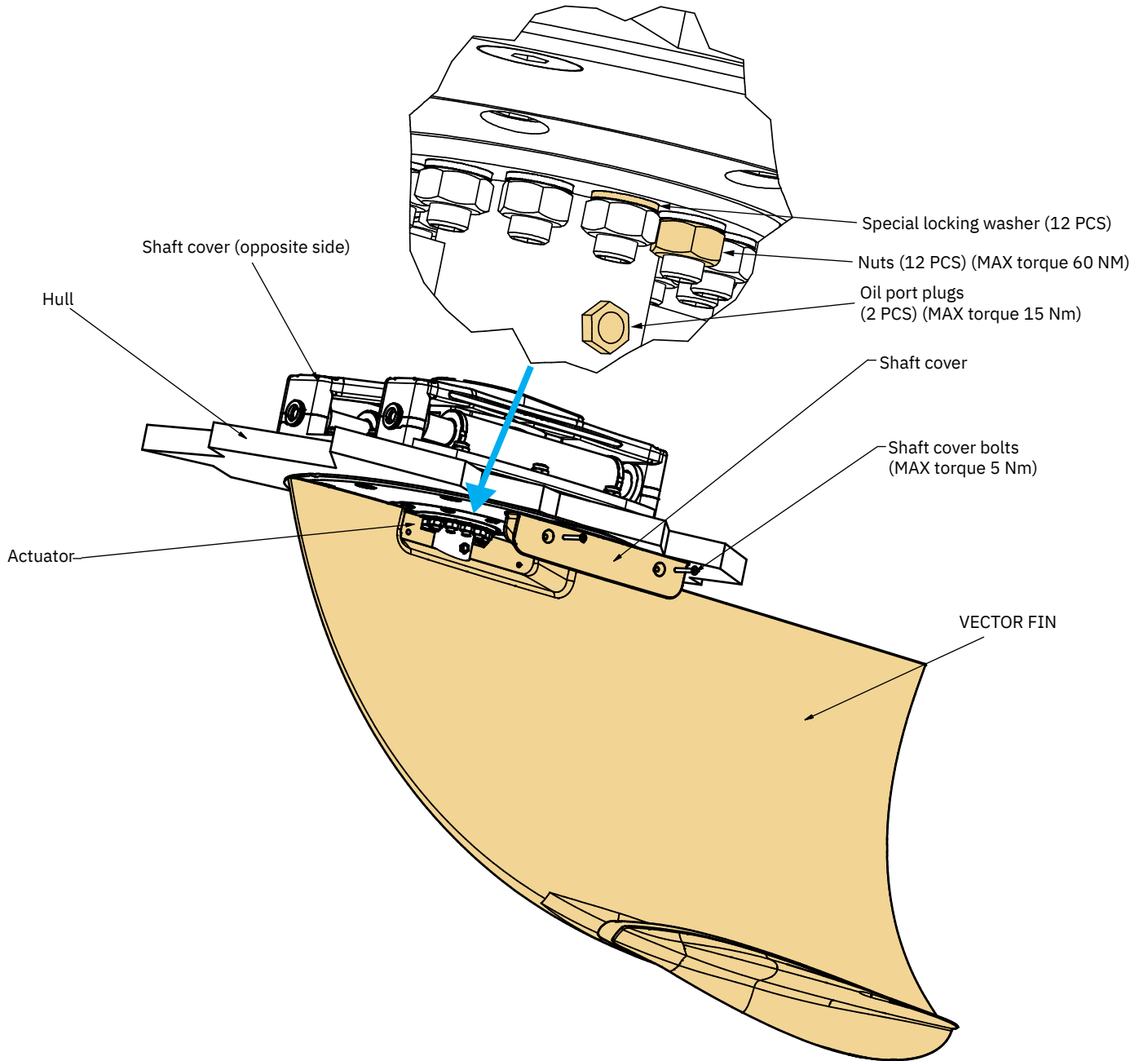

Correct actuator position for fin shaft installation

The following figures illustrate the position the stabilizer actuator assembly cylinders must be positioned in relation to the fully outboard position of the relevant fin.

When viewed and seen from inside/above the relative Stabilizer Actuator assembly:

- Rotate the Port Actuator fully to clockwise.
- Rotate the Starboard Actuator Fully counter clockwise.
- See Transversal fin positioning section.

IMPORTANT

During FIN INSTALLATION procedure, fins/actuators can/will move, ensure that health and safety measures will be taken

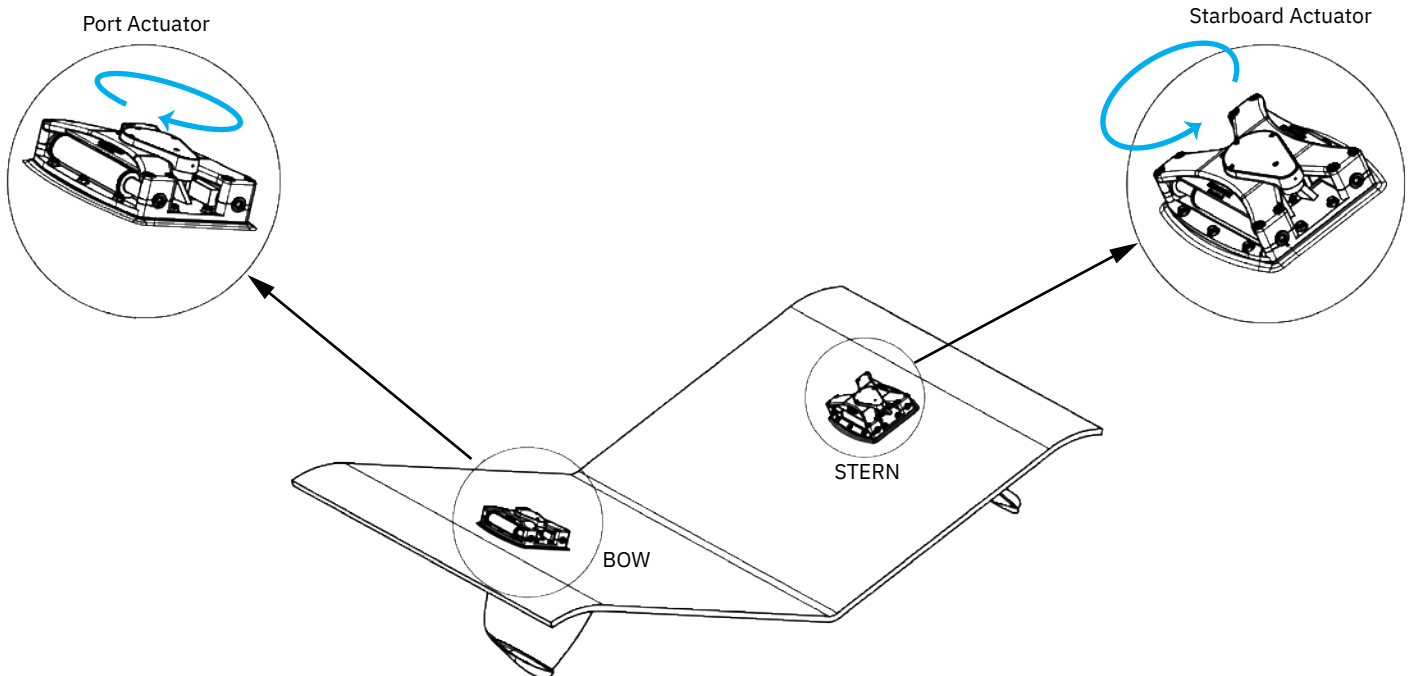

MG_0241

WARNING

A hand oil pump (Installation tool kit, Item nr VFT55) must be used to achieve the fin installation. The pump should only be operated by qualified personnel that follow the pump manual operating instruction and health and safety directives.

Installation of the fin assemblies

1. Place correct fin on a pallet adjacent to relevant actuator under the yacht for mounting.
2. Locate port and starboard fin valve units.
3. On the fin valve units locate the manual decouple valve.
 - Unlock the valve by turning the 9/16" lock nut anti-clockwise.
 - Open the valve by turning the 3/16" Allen key anti-clockwise.
4. Use a 36 socket and ratchet on the large nut that is welded to the actuator port cover to move the actuator to the most outboard position. See step 22-27.
 - Unscrew all nuts and washers.
 - Remove the port cover.
 - Inspect and clean the internal hub.

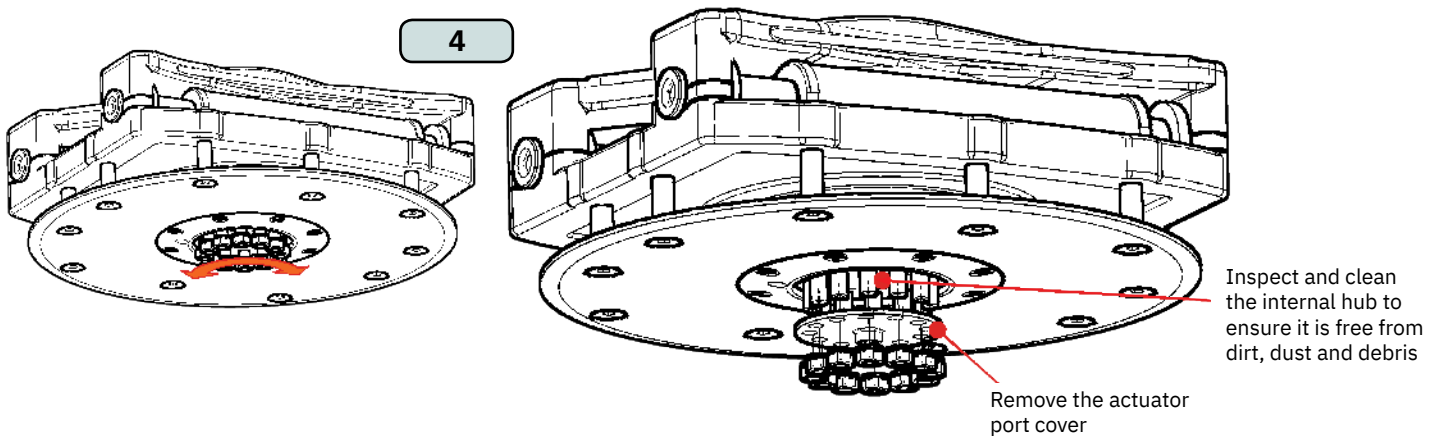
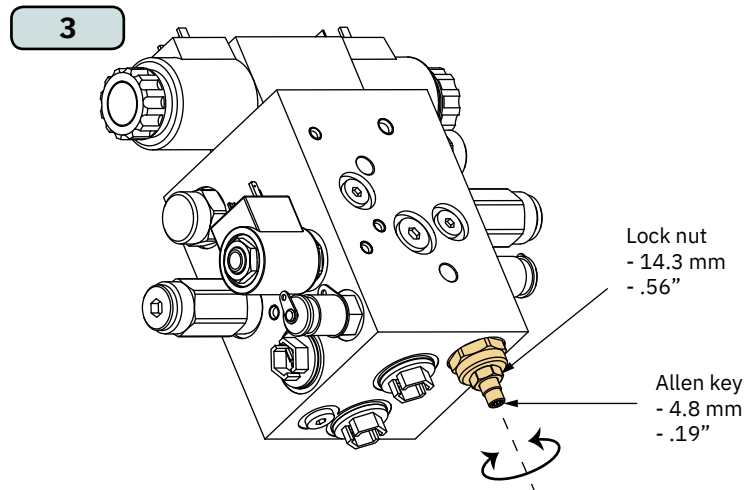

MG_0243

5. Remove shaft covers from fin using a 4mm Allen key.
6. Remove protective covering from the fin shaft cone and ensure it is clean. Clean and degrease the angled surface.
(NB: The protective cover can easily be removed by blowing air using an air pressure gun into the bottom hole of the cover.)
7. Lubricate the shaft with hydraulic oil (LHMF300).

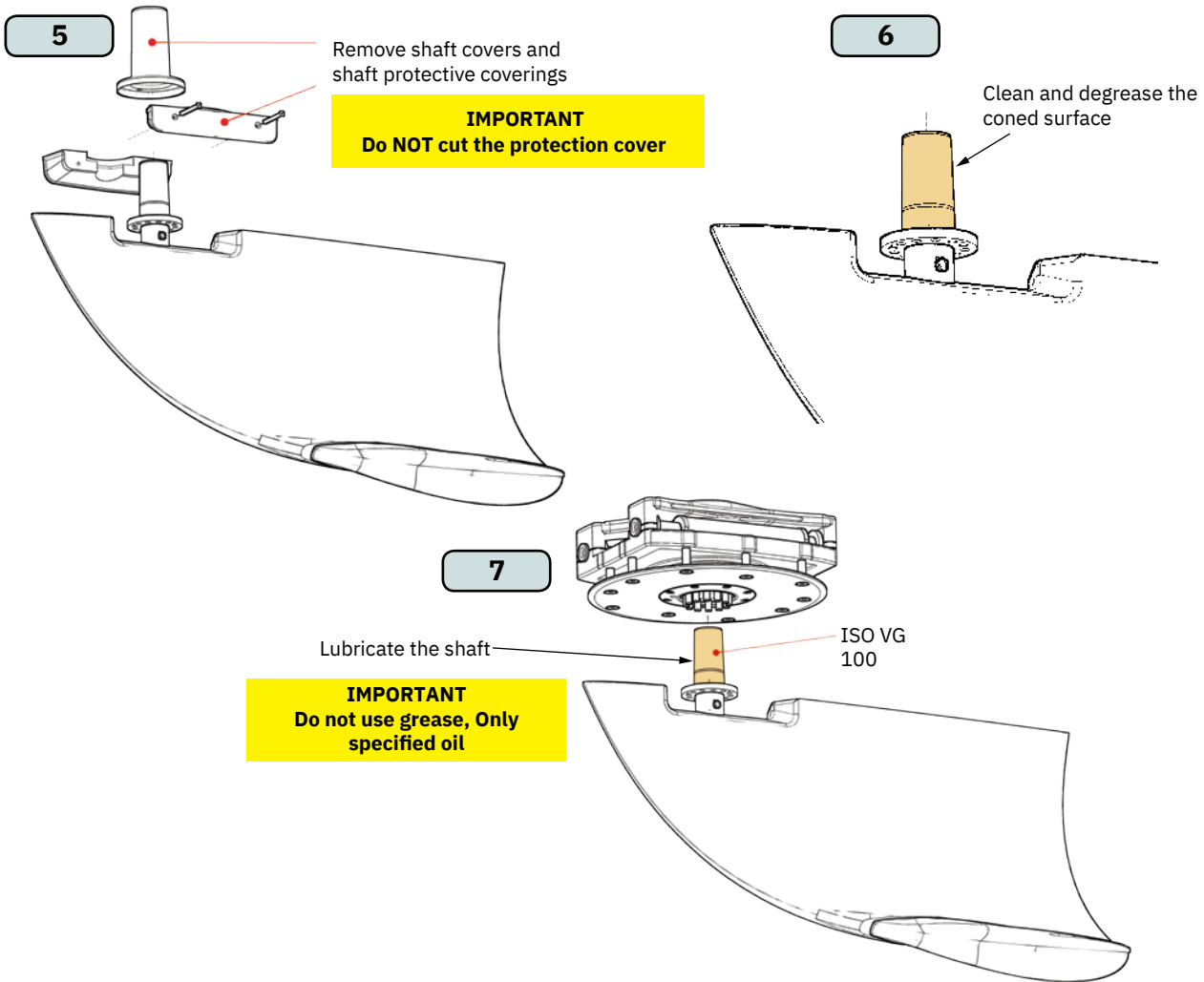

MG_0244

8. When handling the fin assembly, ensure enough manpower is available to assist with the careful insertion and alignment positioning avoiding any unnecessary damage to the shaft.
 - Lift the correct handed fin assembly in the appropriate direction and insert the fin shaft into the actuator.
 - Fit two nuts with washers back onto the securing bolts opposite each other to prevent the fin from falling.
9. Remove both oil port plugs from where the shaft enters the fin.

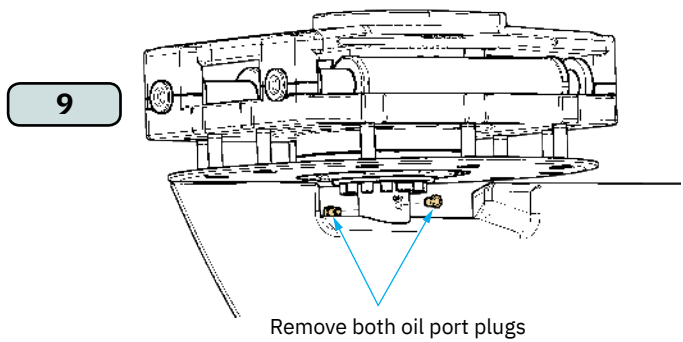
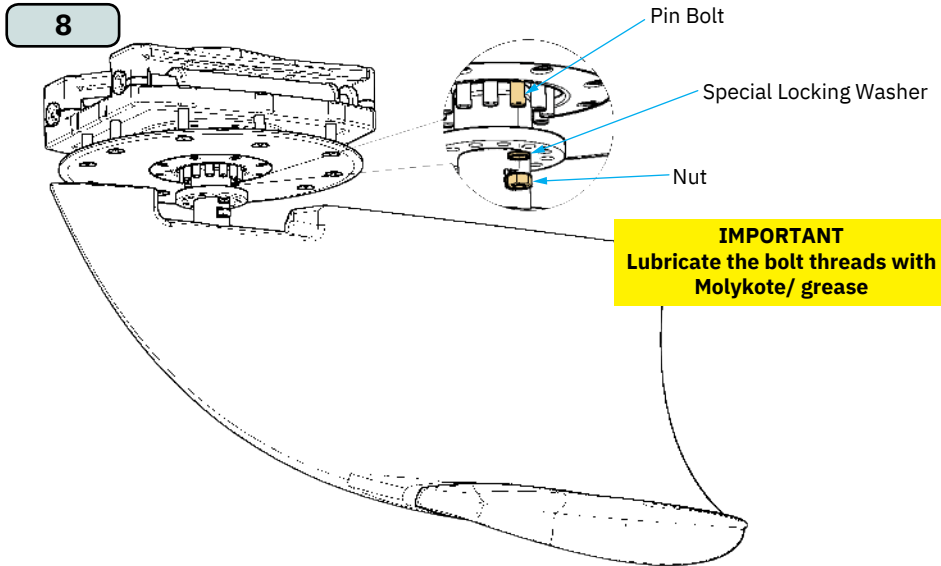

MG_0245

10. Assemble the high-pressure pump according to the manual included with the pump.
 - a. Connect the high-pressure hose.
 - b. Fill up the container with oil.
 - c. Use the pump to bleed out the air in the hose.
 - d. When free oil flows connect the hose to the shaft ON fitting.
 - e. Fitting to shaft
11. Lock the actuator cylinders in its absolute setting then also position the fin as far outboard as possible without hitting the outer edge of the hull.

10

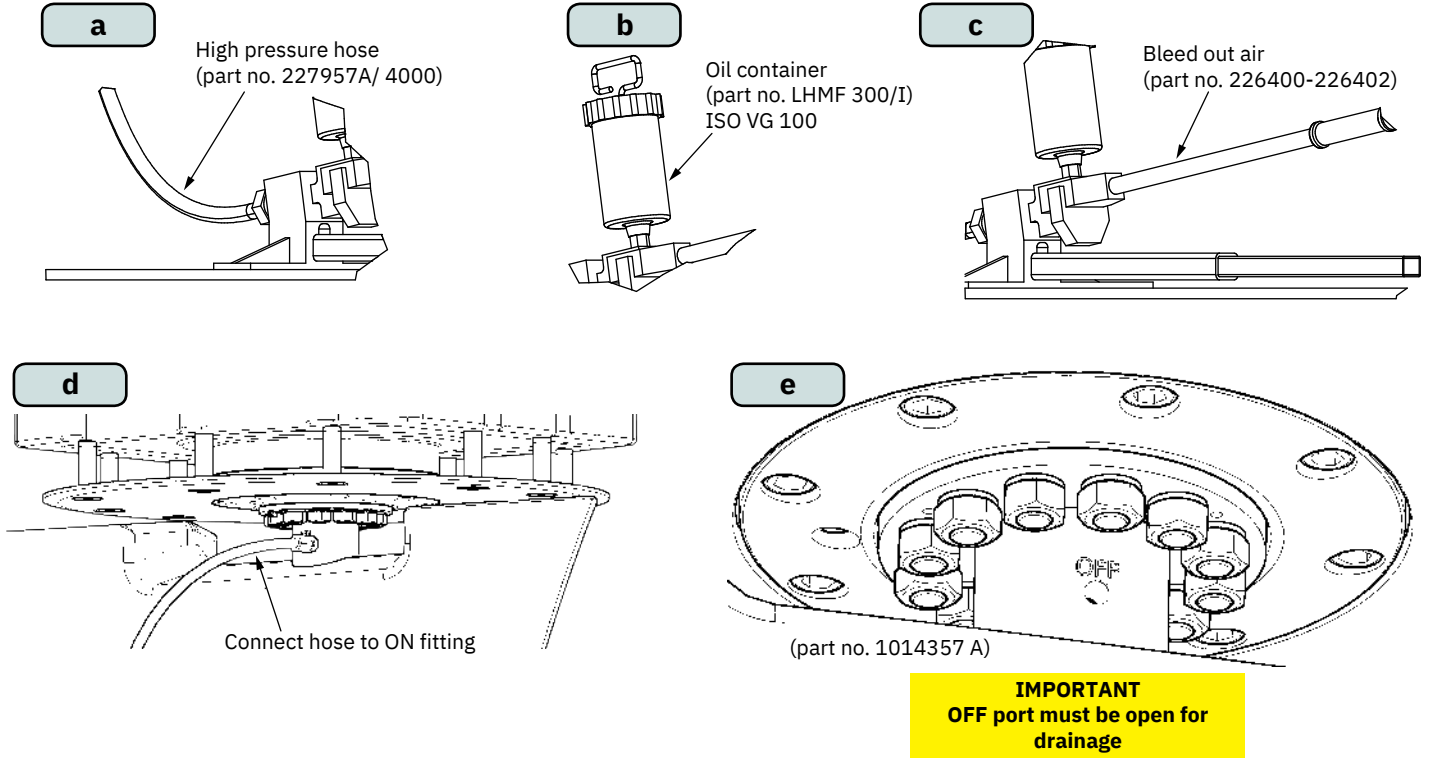

11

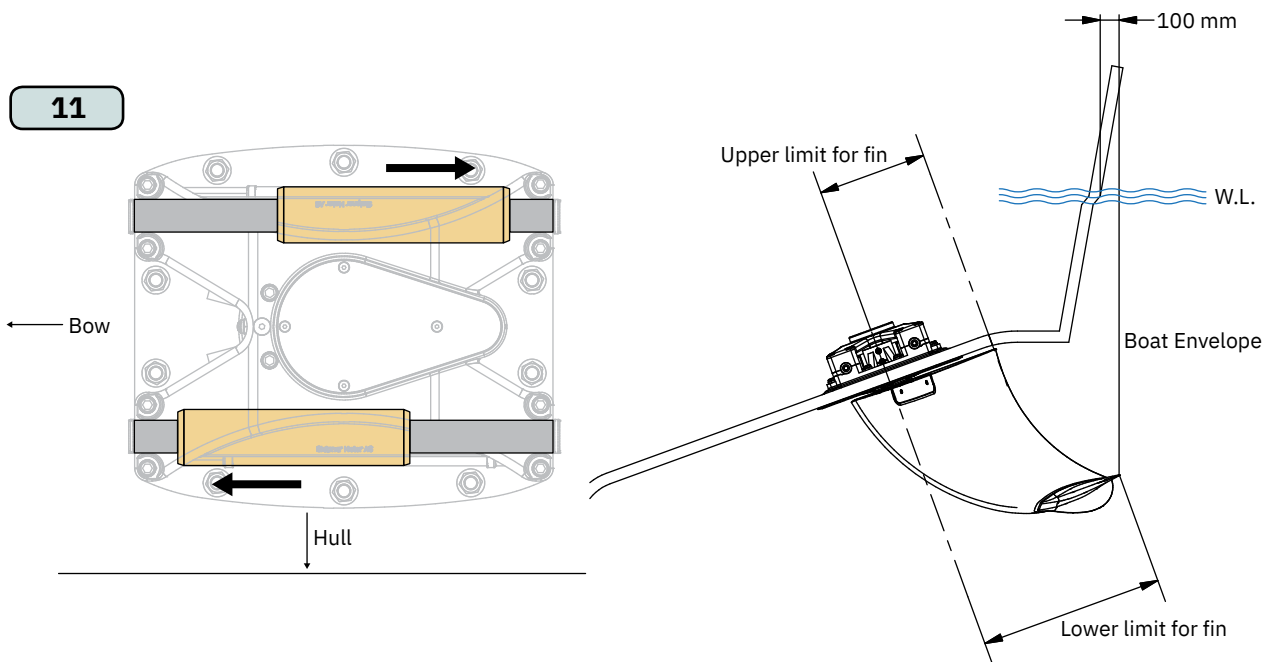

17. Re-tighten the manual decouple valve from Step 3 on the fin valve unit.
18. Refit the ON and OFF plugs into their position 15 min after fin drive up procedure is completed in step 16.
19. Loosely place the shaft protectors and inspect the top face to see if it will rub against any section of the actuator face. If rubbing will occur grind and sand off material on the shaft protectors to remove enough material to ensure clearance.
20. Secure shaft protectors using a 4mm Allen key.

17

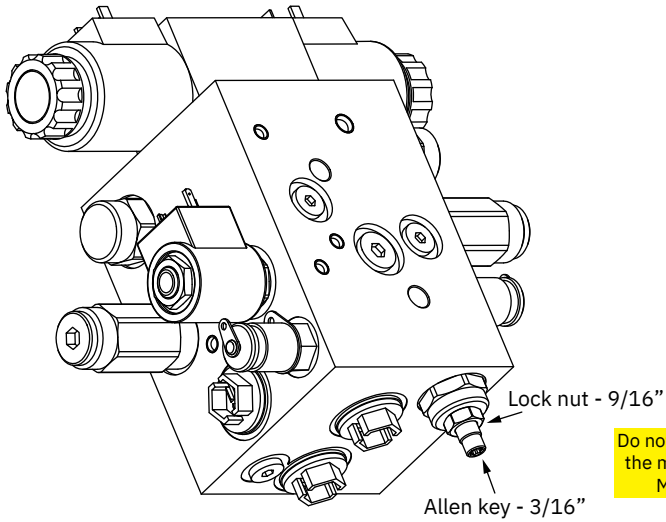

Do not over-tighten
the manual valve.
Max 7 Nm

18

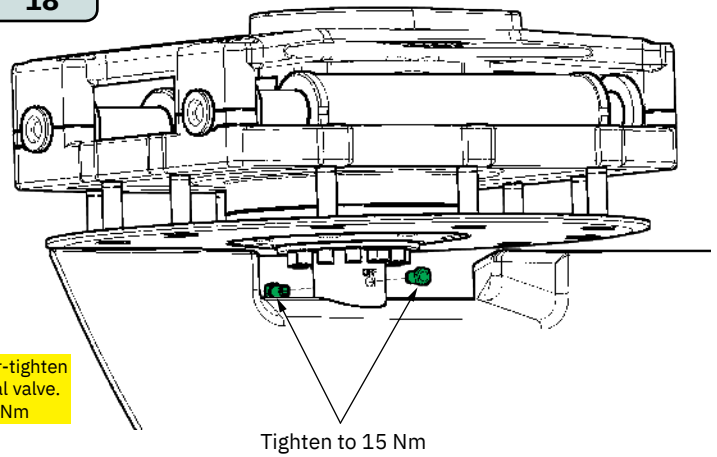

19

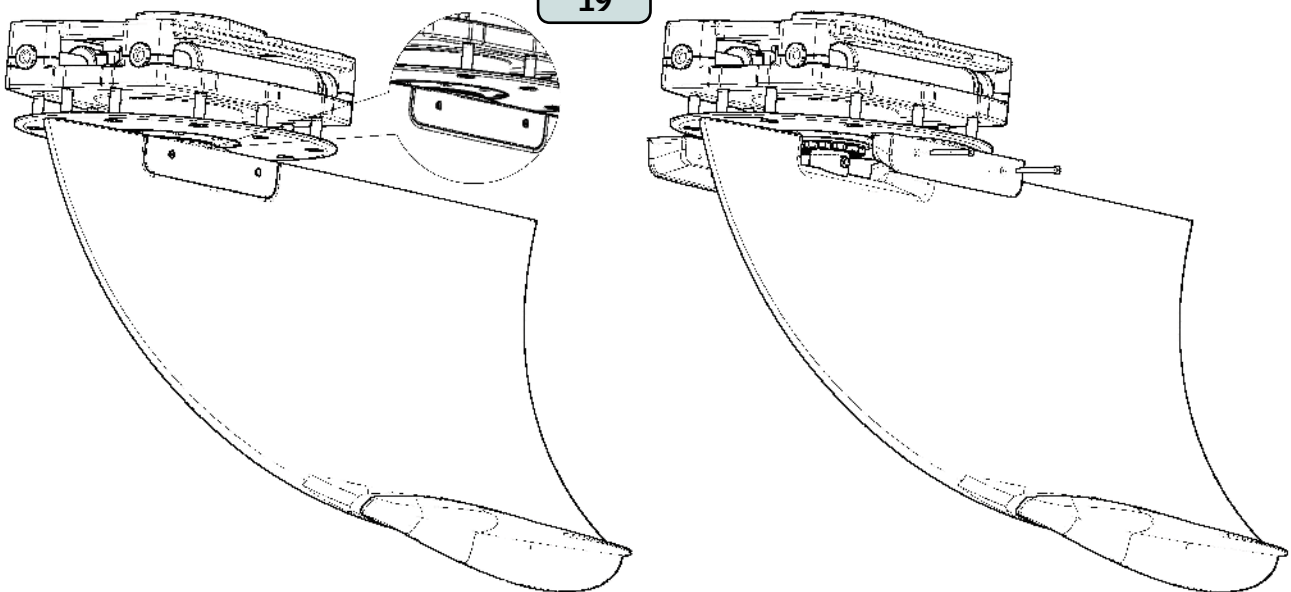

20

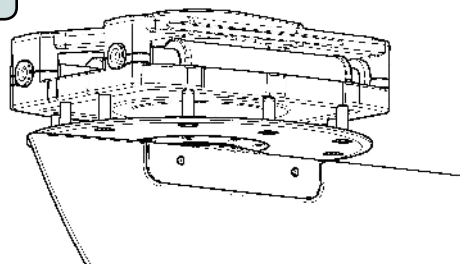

Fin Location Label

After final installation of the fins place the Fin Location Labels to appropriately identify the location of the fins underwater.

Safety Labels

To ensure crane operators and swimmers are aware of the fin's location and operation area, please mount the safety labels on the hull



Adjustable length, fits all Sleipner Vector Fins™.

For application, get your ✂ and follow instructions in the manual.

Use sissors to cut the end arrow symbols on the label.

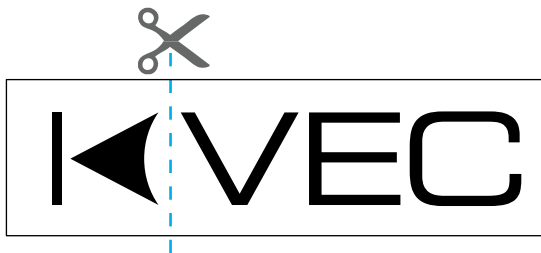

Place the label to the hull and place the end arrow labels to cover the length of the stabliser fin.



21. On the stabilizer panel, Touch HOME.
22. Touch STARTUP and MAINTENANCE
23. Touch STARTUP (Password is 1234 - enter)
24. Touch FIN INSTALLATION
25. Touch MOVE ACTUATORS MANUALLY (This allows you to open/FLOAT actuators from the panel, without the need to manually open the fin valve unit described in step 3/18. (Step 3 and 18 can be excluded). It requires that Stabilizer control and hydraulic system is wired and connected with 24V power supply.)
26. (a) Touch FLOAT - turn actuators to out most position according to step6
 (b) Touch LOCK when desired position is achieved
 (c) Install fins according to step 1-20
 (d) Touch RETURN when completed

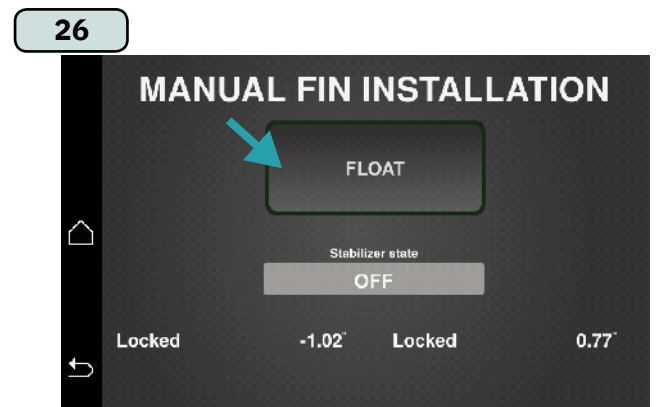
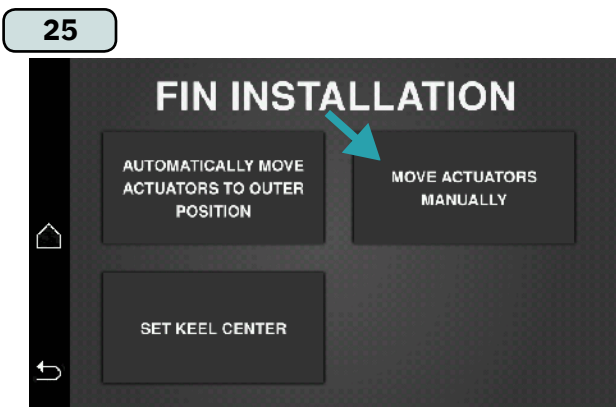
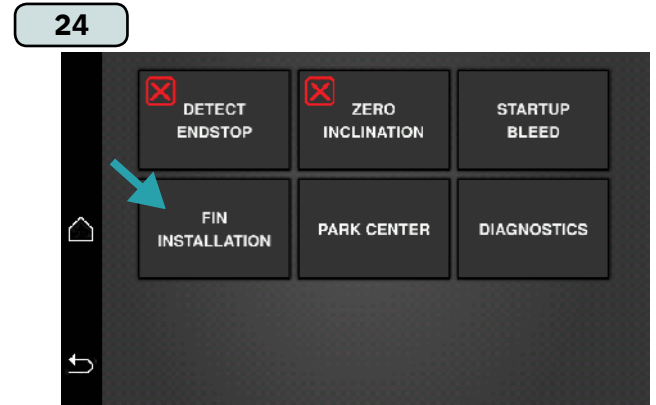
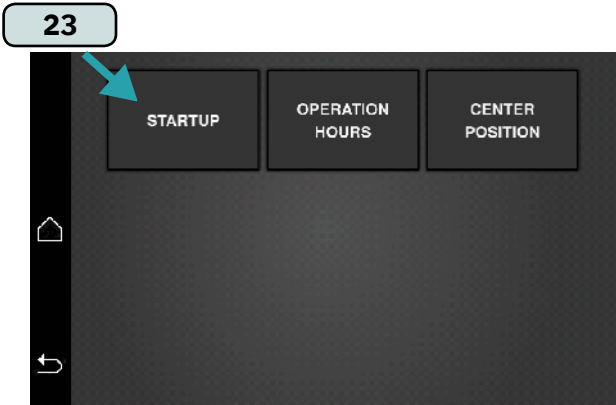
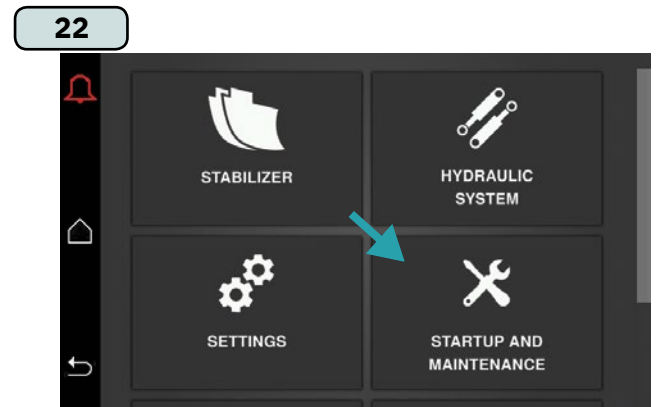
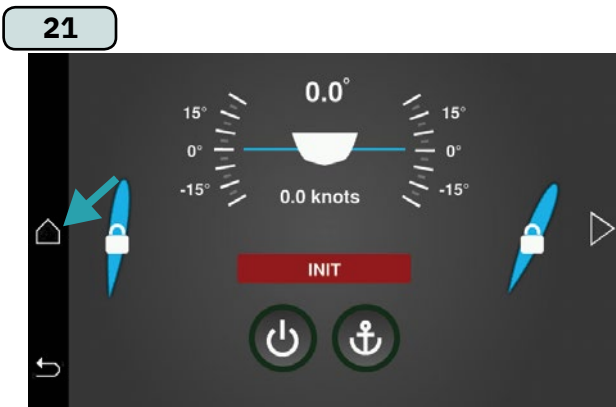

MG_0265

Fin/Actuator settings (Scroll down menu)

- 1. STOP ANGLE value
- 2. FIN POSITION P FACTOR value
- 3. FIN POSITION I FACTOR value
- 4. FIN POSITION D FACTOR value

These settings are boat dependant and necessary to achieve optimum performance of the system for a given application. Settings are to be changed only when requested by authorized SP personnel.

- 5. FIN ACT TYPE select actuator
- 6. FIN TYPE select fin

Select the actuator and fin size installed in Detect End-stop section.

Pre-STARTUP is now completed. Go to STARTUP.

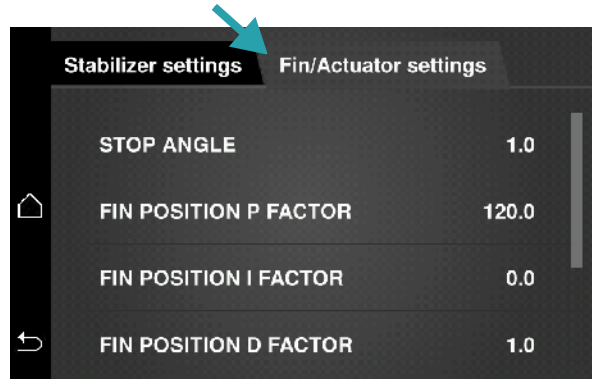

IMPORTANT

Before running or making setting adjustments in **STARTUP**, **SEA TRIAL** and **Parameter SETTINGS** ensure that:

- Complete Hydraulic and Electrical system is up and running
- Stabilizer system (also At Anchor) is in **OFF** status on the panel.
- AC pump is **AUTO/ON** or **PTO** is **ON**.

WARNING

During **STARTUP** procedure fins/actuators will move, ensure that health and safety measures will be taken

STARTUP procedure

From HOME menu:

1. Touch **STARTUP** and **MAINTENANCE**
2. Touch **STARTUP** (1234 - enter)
3. Touch **STARTUP BLEED**

Check Pressure On Accumulator Gauge

**(NB: Ac Pump Standby Pressure
(75 BAR VF650, 90 BAR VF800/VF1350, 100 BAR VF1050, 110 BAR VF1650/VF1950 Vector Fins.)**

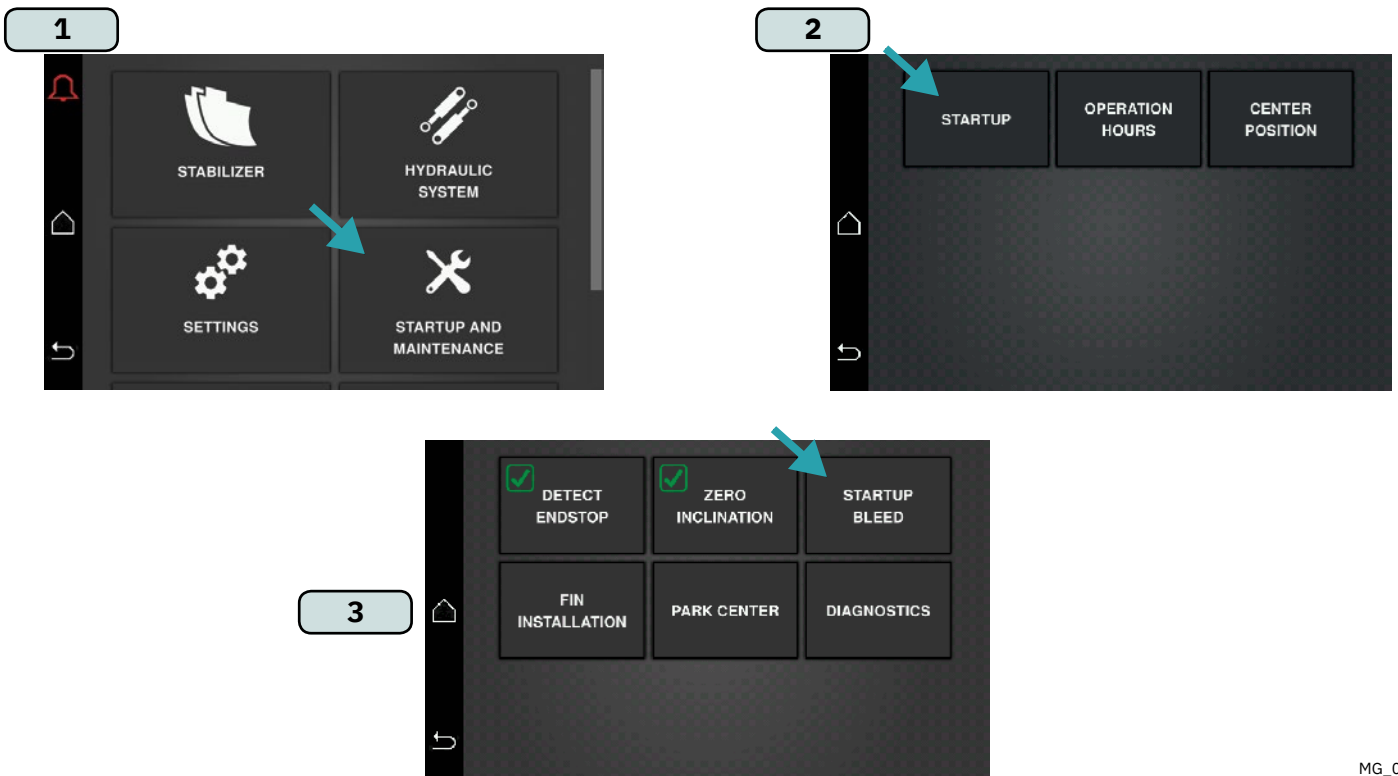

MG_0275

1. Touch START (Bleed actuators)

WARNING
Fins/actuators will move

Bleeding procedure will take some time.

The bleeding procedure is used to circulate oil through the hoses to flush any gas (air) out of the hydraulic system. Hose/piping routing might require the bleeding to be performed several times.

Proceed to the DETECT ENDSTOP menu.

Return to STARTUP screen

2. Touch DETECT ENDSTOP
3. Ensure correct Actuator and Fin type selected.
Touch NEXT
4. Touch START

WARNING
Fins/actuators will move

5. The end stop detection is required as it defines the actuator stroke. When the procedure is complete, press the RETURN arrow to go back to the STARTUP menu:

Proceed to the ZERO INCLINATION menu.

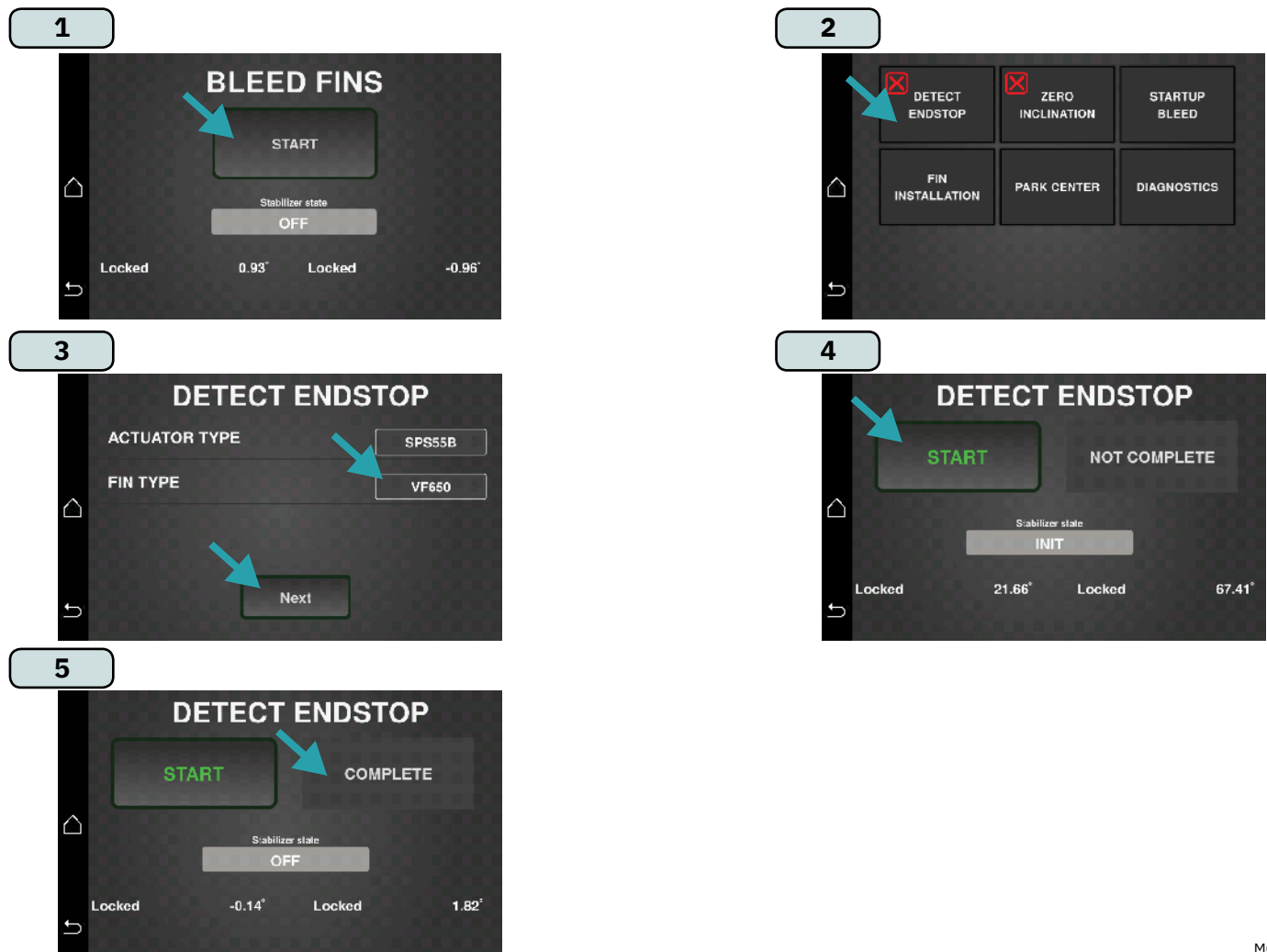

Return to STARTUP screen

1. Touch ZERO INCLINATION
2. Select the SCU MOUNT DIRECTION.
SCU is mounted either facing bow or facing aft of the yacht.
Ensure the yacht is level and not rolling before setting the 0° keel:
3. Touch START
When procedure is complete:
4. Touch RETURN
Return to STARTUP screen
5. Touch PARK CENTRE
6. Touch USE KEEL CENTRE (Recommended) (If on shore)

When Stabilizer system is turned off or in backing mode the fins will now be locked in center position that was performed during fin installation.

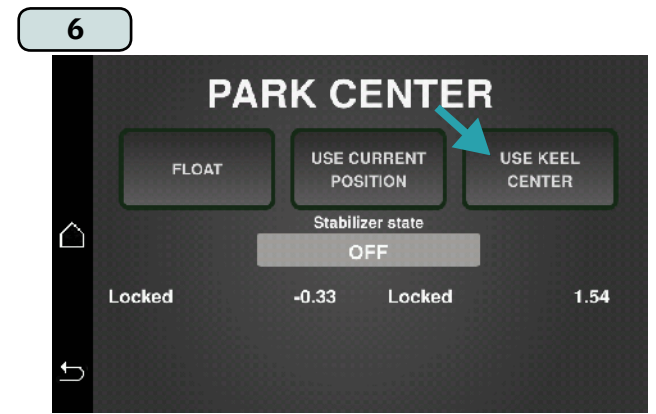
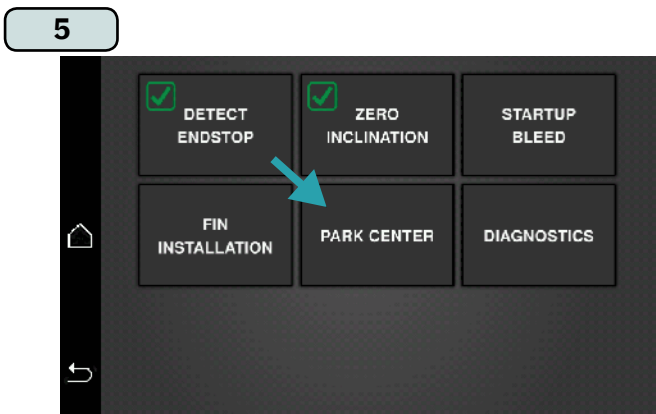
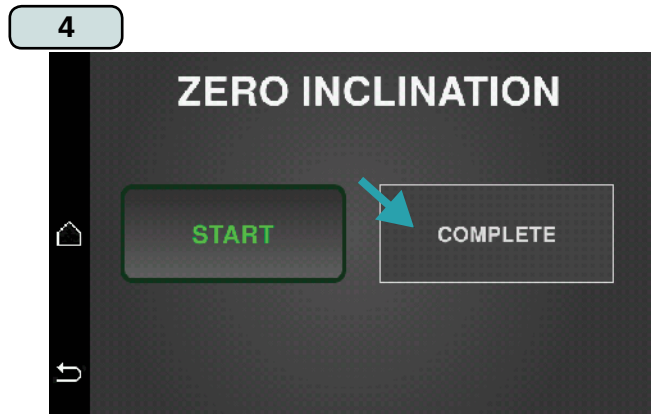
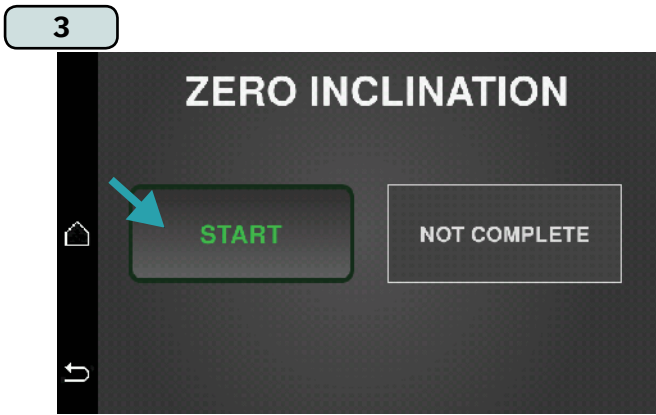
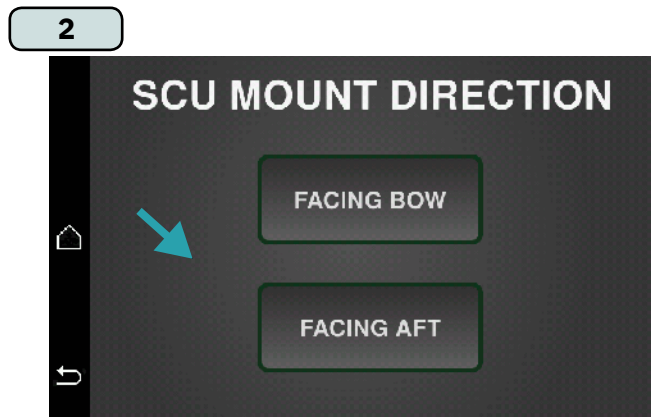
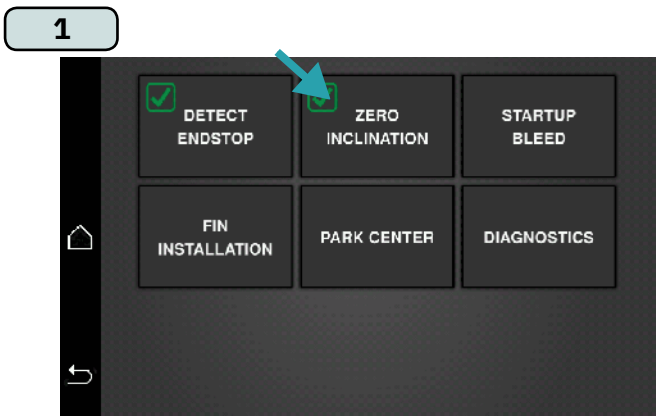

MG_0277

If you for some reason want to adjust or use another PARK CENTRE position, it can be performed from this section:

1. Touch related fin value to adjust PARK CENTRE position.
(NB: Values shown are fin position with actuator mechanical centre as reference.)
 Change value on related fins to desired position.
2. Touch ENTER when completed.
 If you want to adjust PARK CENTRE to a given speed:
3. Touch FLOAT
 Proceed to wanted speed When desired speed is achieved:
4. Touch USE CURRENT POSITION and then Touch LOCK.
(NB: Current fin positions are shown i red values. (When in FLOAT state))
5. Touch RETURN to proceed.

STARTUP is now complete, Proceed to SEATRIAL

1

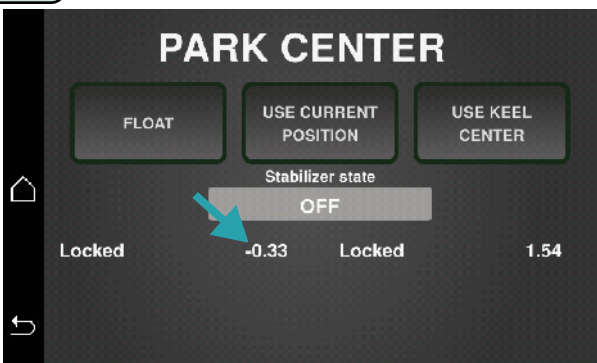

2

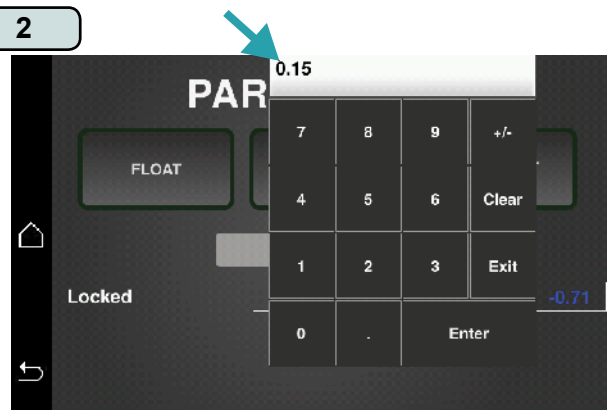

3

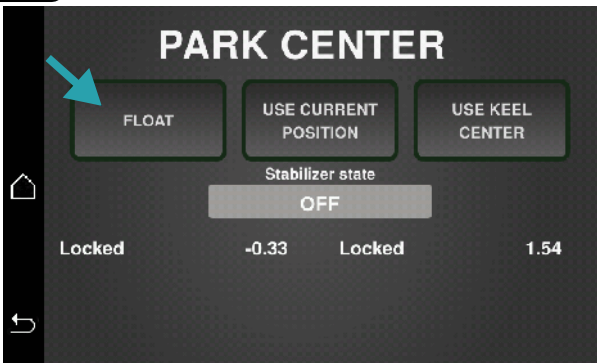

4

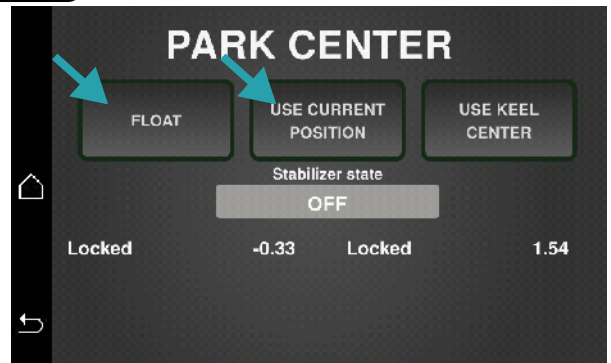

5

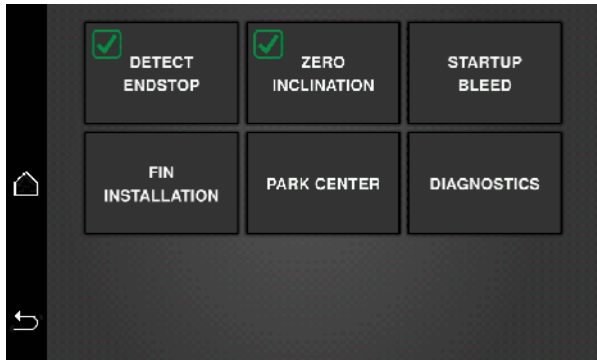

Dynamic fin position setup

The dynamic setup is required to get the best Vector fin performance benefits. A sea trial is required to find the free float positions of the fins at different speeds, and to tune to optimum position for a given speed. It is preferable to have flat sea for the dynamic setup sea trial, to minimize boat roll that will influence fin position.

To find the free float positions, it is necessary to float the fins, start the logger, and take the vessel to maximum speed. Then register the positions at different speeds, starting with the highest and choose speeds steps according to the vessel performance. The position is interpolated between the different speeds, so it is important to have one speed before the planning threshold and one after, as the water flow over the fins often change much during the transition to planning mode.

When all speeds/positions have been set, stop the logger.

Dynamic fin position setup continues:

When the free float positions have been recorded, the following table can be used as a starting point for fin position adjustment: (Do NOT press STORE after adjusting with these values)

	Speed (knots)	Port fin adjustment	Starboard fin adjustment
1	12	-3°	+3°
2	18	-4°	+4°
3	24	-5°	+5°
4	30	-4°	+4°
5	36	-3°	+3°

Some boats will require more or less adjustment for optimum performance. Too much correction is to be avoided, as the actuator needs some torque reserve to be able to counter roll.

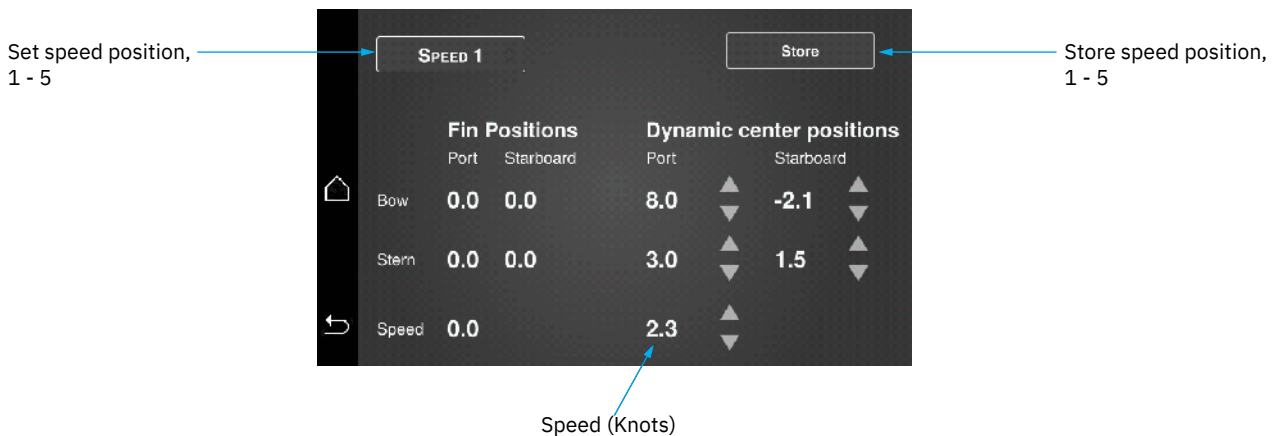

Start-up checks Actuators

- Actuator Manual Decouple Valve Tight.
- Check Electric operated decouple valve (coil nut) is tightened Under 6.8-9.5 Nm.
- Check hose spec from combiner to fin valve(Less than 2.5m)(Recommended).
- Actuator Hose Connections Tight/Clear Port/Stb.
- Hoses have full range of movement. ***excluding SPS-B 55**
- Cylinder rods clean, and without damages/scratches.
- Actuator Electrical Connections Clear.
- Actuator Encoder Belt, Wheels ok and Belt Tight.
- Actuator Bonded to the boats electrical system.
- Actuators clear of Boat Structure.

Start-up checks Fin valve unit

- Fin Valve Manual Decouple Valve Tight.
- Fin Valve Check Hose Connections Port/Stb.
- Fin Valve Electrical Connections Correct.

Start-up checks Accumulator block

- Accumulator Block Manual Decouple Valve Tight.
- Accumulator Block Hose Connections Ok.
- Accumulator Block Electrical Connections Correct.
- Accumulator Pressure Transmitter Reading Correct.

Start-up checks Electrical components

- Check Power Feed is Active.
- SCU and FCU Electrical Connections.
- GW-1 and GPS Connections Correct and Valid Signal.

Start-up checks Cooling pump

Electric:

- PHC-3 settings. See PHC-3 manual.
- Check Cooling pump connections are correct and pump runs in correct direction.

Hydraulic:

- PHC-3 settings. See PHC-3 manual.
- Check connections and drive direction

Both Electric and Hydraulic:

- Check cooling pump is installed below waterline.
- No air traps in the water lines(continuous rise).
- Cooling water discharge should have minimum resistance/back pressure.
(Discharge to engine exhaust will cause problems for the water pump).
- Pre-startup from PHC-3 manual is performed. (MANUAL OPERATION – START COOLING PUMP)
- Cooling pump set to auto when performing Fin Installation from panel. See PHC-3 manual.

Start-up checks AC pump

- AC Pump Clockwise.
- Ac Pump Standby Pressure
(3.5 kW motor 75 bar, 4.6 kW motor 90 bar, 5.5 kW motor 90 bar, 5.5 kW motor VF1050 100 bar, 7.5 kW motor 100 bar, 11 kW motor 90 bar, 15 kW 1-phase 100 bar, 15 kW motor 3-phase 110 bar).

Start-up checks PTO pump

- Ensure correct pressure according to specific system drawings

Start-up checks Hydraulics

- Check hose connections, all connections may require re-tightening

The stabilizer has been installed as per the instructions in this manual and all points in checklist above have been controlled.

Signed:

Date:

Extra pre-delivery tests by installer / yard who does not use other quality control systems !

Stabiliser type:

Serial number:.....

Date of delivery:.....

Other comments by installer:

.....

.....

Find your local professional dealer from our certified worldwide network for expert service and support. visit our website www.sleipnergrou.com/support

Product Spare Parts and Additional Resources

For additional supporting documentation, we advise you to visit our website www.sleipnergrou.com and find your Sleipner product.

Warranty statement

1. Sleipner Motor AS (The “Warrantor”) warrants that the equipment (parts, materials, and embedded software of products) manufactured by the Warrantor is free from defects in workmanship and materials for purpose for which the equipment is intended and under normal use and maintenance service (the “Warranty”).
2. This Warranty is in effect for two years (Leisure Use) or one year (Commercial and other Non-leisure Use) from the date of delivery/purchase by the end user, with the following exceptions;
 - (a) For demonstration vessels, or vessels kept on the water, the dealer is considered as the end user from 6 months after their launch of the vessel;
 - (b) The warranty period starts no later than 18 months after the first launch of the vessel.
 Please note that the boat manufacturer and dealer must pay particular attention to correct maintenance and service both by the products manuals as well as general good practice for the location the boat is kept in the period the boat is in their care. In cases where the 6 and 18 months grace periods for boat builders and dealers are passed, it is possible to obtain a full warranty upon inspection and approval of the warrantor or such representative.
3. Certain parts, classified as wearable or service parts, are not covered by the warranty. A failure to follow the required maintenance and service work as described in the product manual render all warranty on parts or components directly or indirectly affected by this void. Please also note that for some parts, time is also a factor separately from actual operational hours.
4. This Warranty is transferable and covers the equipment for the specified warranty period.
5. The warranty does not apply to defects or damages caused by faulty installation or hook-up, abuse or misuse of the equipment including exposure to excessive heat, salt or fresh water spray, or water immersion except for equipment specifically designed as waterproof.
6. In case the equipment seems to be defective, the warranty holder (the “Claimant”) must do the following to make a claim:
 - (a) Contact the dealer or service centre where the equipment was purchased and make the claim. Alternatively, the Claimant can make the claim to a dealer or service centre found at www.sleipnergrou.com. The Claimant must present a detailed written statement of the nature and circumstances of the defect, to the best of the Claimant’s knowledge, including product identification and serial nbr., the date and place of purchase and the name and address of the installer. Proof of purchase date should be included with the claim, to verify that the warranty period has not expired;
 - (b) Make the equipment available for troubleshooting and repair, with direct and workable access, including dismantling of furnishings or similar, if any, either at the premises of the Warrantor or an authorised service representative approved by the Warrantor. Equipment can only be returned to the Warrantor or an authorised service representative for repair following a pre-approval by the Warrantor’s Help Desk and if so, with the Return Authorisation Number visible postage/shipping prepaid and at the expense of the Claimant.
7. Examination and handling of the warranty claim:
 - (a) If upon the Warrantor’s or authorised service Representative’s examination, the defect is determined to result from defective material or workmanship in the warranty period, the equipment will be repaired or replaced at the Warrantor’s option without charge, and returned to the Purchaser at the Warrantor’s expense. If, on the other hand, the claim is determined to result from circumstances such as described in section 4 above or a result of wear and tear exceeding that for which the equipment is intended (e.g. commercial use of equipment intended for leisure use), the costs for the troubleshooting and repair shall be borne by the Claimant;
 - (b) No refund of the purchase price will be granted to the Claimant, unless the Warrantor is unable to remedy the defect after having a reasonable number of opportunities to do so. In the event that attempts to remedy the defect have failed, the Claimant may claim a refund of the purchase price, provided that the Claimant submits a statement in writing from a professional boating equipment supplier that the installation instructions of the Installation and Operation Manual have been complied with and that the defect remains.
8. Warranty service shall be performed only by the Warrantor, or an authorised service representative, and any attempt to remedy the defect by anyone else shall render this warranty void.
9. No other warranty is given beyond those described above, implied or otherwise, including any implied warranty of merchantability, fitness for a particular purpose other than the purpose for which the equipment is intended, and any other obligations on the part of the Warrantor or its employees and representatives.
10. There shall be no responsibility or liability whatsoever on the part of the Warrantor or its employees and representatives based on this Warranty for injury to any person or persons, or damage to property, loss of income or profit, or any other incidental, consequential or resulting damage or cost claimed to have been incurred through the use or sale of the equipment, including any possible failure or malfunction of the equipment or damages arising from collision with other vessels or objects.
11. This warranty gives you specific legal rights, and you may also have other rights which vary from country to country.

Patents

At Sleipner we continually reinvest to develop and offer the latest technology in marine advancements. To see the many unique designs we have patented visit our website www.sleipnergrou.com/patents

© **Sleipner Group**, All rights reserved
The information given in the document
was right at the time it was published.
However, Sleipner Group cannot
accept liability for any inaccuracies or
omissions it may contain. Continuous
product improvement may change the
product specifications without notice.
Therefore, Sleipner Group cannot accept
liability for any possible differences
between product and document.

**Register your product and learn more
at www.sleipnergroun.com**



SLEIPNER GROUP

P.O. Box 519

N-1612 Fredrikstad

Norway

www.sleipnergroun.com

Made in Norway

