

Keep this
manual onboard!



User Manual

Including Installation For S-Link Gateway
GW-2Y



SLEIPNER GROUP

P.O. Box 519

N-1612 Fredrikstad

Norway

www.sleipnergroup.com

DOCUMENT ID: 7807

REVISION: 02

DATE: 2024

LANGUAGE: EN



To download your language go to www.sleipnergroup.com

Contents

Installation Manual

Introduction	3
CAN Interface	3
NMEA0183 Interface.....	3

Installation Guide

Responsibility of the Installer	4
S-Link Gateway Installation	5
GW-1 Gateway Measurements	6
Technical Specifications	6
S-Link System Description	7
Typically NMEA2000® Connection Diagram	8

Service and Support	9
Product Spare Parts and Additional Resources	9
Warranty Statement	9

Introduction

MC_0761

S-Link gateway GW-2Y is a device for connecting Yanmar J1939 bus to the S-Link bus. Connect an S-Link spur cable from the gateway to the S-Link backbone, and non S-Link equipment to the CAN Interface M12 male connector or NMEA0183 GPS antenna to the NMEA0183 connector.

Power to the gateway is supplied from the S-Link so no external power is required.

CAN Interface

MC_0761

Connection

The GW-2Y does not feed any power to the CAN-bus and connected devices has to be power feed from elsewhere. The GW-2Y does not include any termination resistor on the M12 male connector output, so terminating resistors is required on the CAN-bus. CAN-L & CAN-H are galvanic isolated. Sleipner Motor AS do not provide cables for the CAN Interface bus.

LED indication

TX LED(Reference 1) off:	Not sending any messages.
TX LED flashing:	Flashing at max 100ms on and 100ms off when sending messages.
RX LED (Reference 2) off:	Not receiving any messages.
RX LED flashing:	Flashing at max 100ms on and 100ms off when receiving messages

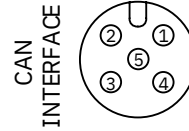

M12 Input Male Connector
(View into connector)
Pin 1 NC
Pin 2 NC
Pin 3 GND
Pin 4 CAN-H
Pin 5 CAN-L

MG_0802

NMEA0183 Interface

MC_0765

Connection

The V OUT pin can feed power to a single GPS antenna with maximum 100mA, and it is internally fused. V OUT is S-link bus voltage. RX A(+) & TX B(-) are galvanic isolated

Baud rate

4800 baud and 38400 baud is supported, and are set automatically.

Supported NMEA0183 sentences

\$GxRMC sentences from all positioning systems is supported.

LED indication (Reference 3)

LED off:	No valid NMEA0183 GPS signals.
LED flashing:	Flashing 100ms on and 100 off for each valid GPS message received. - Valid GPS antenna message at 38400 baud normal flashing on/off (100ms/100ms). - Valid GPS antenna message at 4800 baud normal flashing on/off (100ms/900ms)

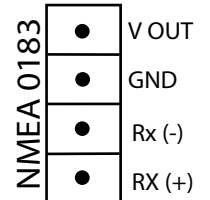

GNSS Antenna Prioritization

GNSS antennas priority sequence is 1. NMEA0183 with 100ms update rate 2. NMEA0183 with 1000ms update rate.

GW-2Y will only forward one of the NMEA2000® GPS antenna signal to S-link if more than one antennas is present on the NMEA2000® bus.

If more than one GW-2Y have GNSS signal(s) then GW-2Y's will prioritize on antenna type from the list above and only one GW-2Y will broadcast GNSS signals on the S-link bus.

All this requires GW-2Y firmware V1.021 or newer.

Status LED (Reference 4)

LED off:	No power to the device.
LED on:	S-Link communication and power OK.
LED flashing (on/off (500ms/500ms)):	No S-Link communication but power is OK.

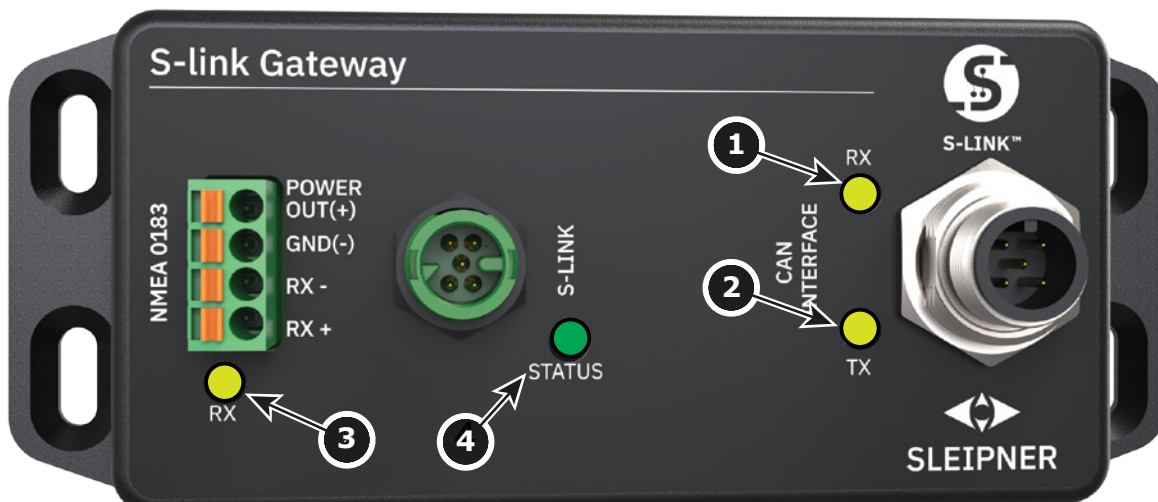

Responsibility of the Installer

MC_0038

The installer must read this document to ensure necessary familiarity with the product before installation.

Instructions in this document cannot be guaranteed to comply with all international and national regulations. It is the responsibility of the installer to follow all applicable international and national regulations when installing Sleipner products.

The recommendations given in this document are guidelines ONLY, and Sleipner strongly recommends that advice is obtained from a person familiar with the particular vessel and applicable regulations.

This document contains general installation instructions intended to support experienced installers. If you are not skilled in this type of work, please contact professional installers for assistance.

If required by local regulation, electrical work must be done by a licensed professional.

Appropriate health and safety procedures must be followed during installation.

Faulty installation of Sleipner products will render all warranties given by Sleipner Motor AS.

Ensure appropriate access to Sleipner products during installation planning for service, inspection and component replacement.

When installing an S-Link™ system connect ONLY original Sleipner S-Link™ products or other authorized control equipment directly to the S-Link™ bus. Connecting non-authorized third-party equipment, it must always be connected through a Sleipner supplied interface product. Any attempt to directly control or connect into the S-Link™ control system without a designated and approved interface will render all warranties and responsibilities of all of the connected Sleipner products. If you are interfacing the S-Link™ bus by agreement with Sleipner through a designated Sleipner supplied interface, you are still required to install at least one original Sleipner control panel to enable efficient troubleshooting if necessary.

MC_0105

Failure to follow the considerations and precautions can cause serious injury, damage and will render all warranties given by Sleipner Motor as VOID.

MC_0411

1. Fasten the GW-2Y box to a solid surface using four mounting screws.
2. Attach the required cables to the GW-2Y.

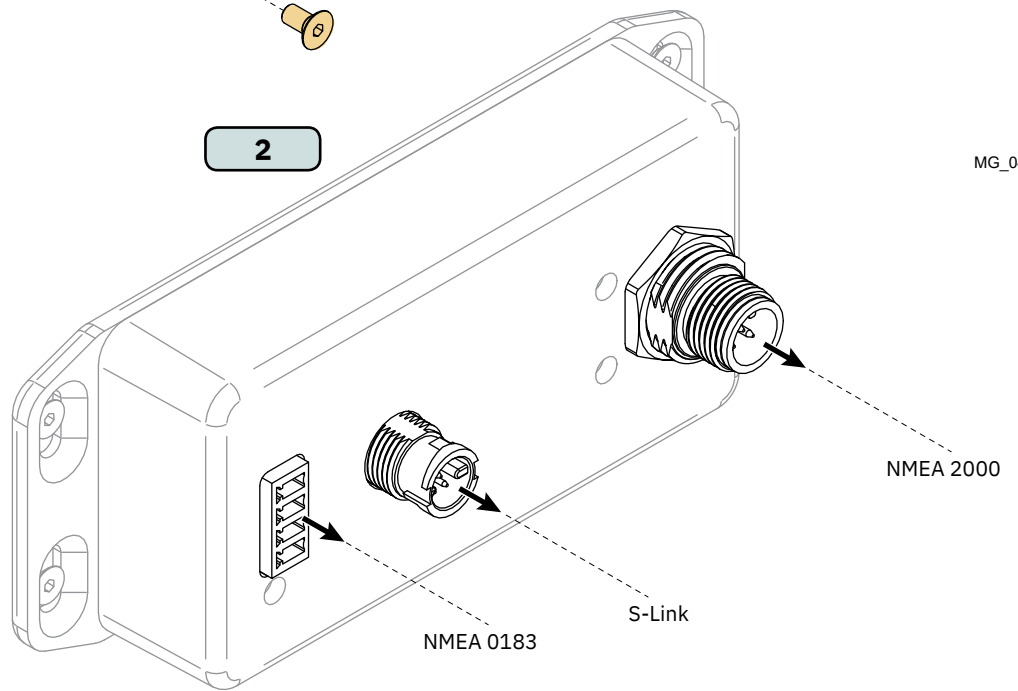
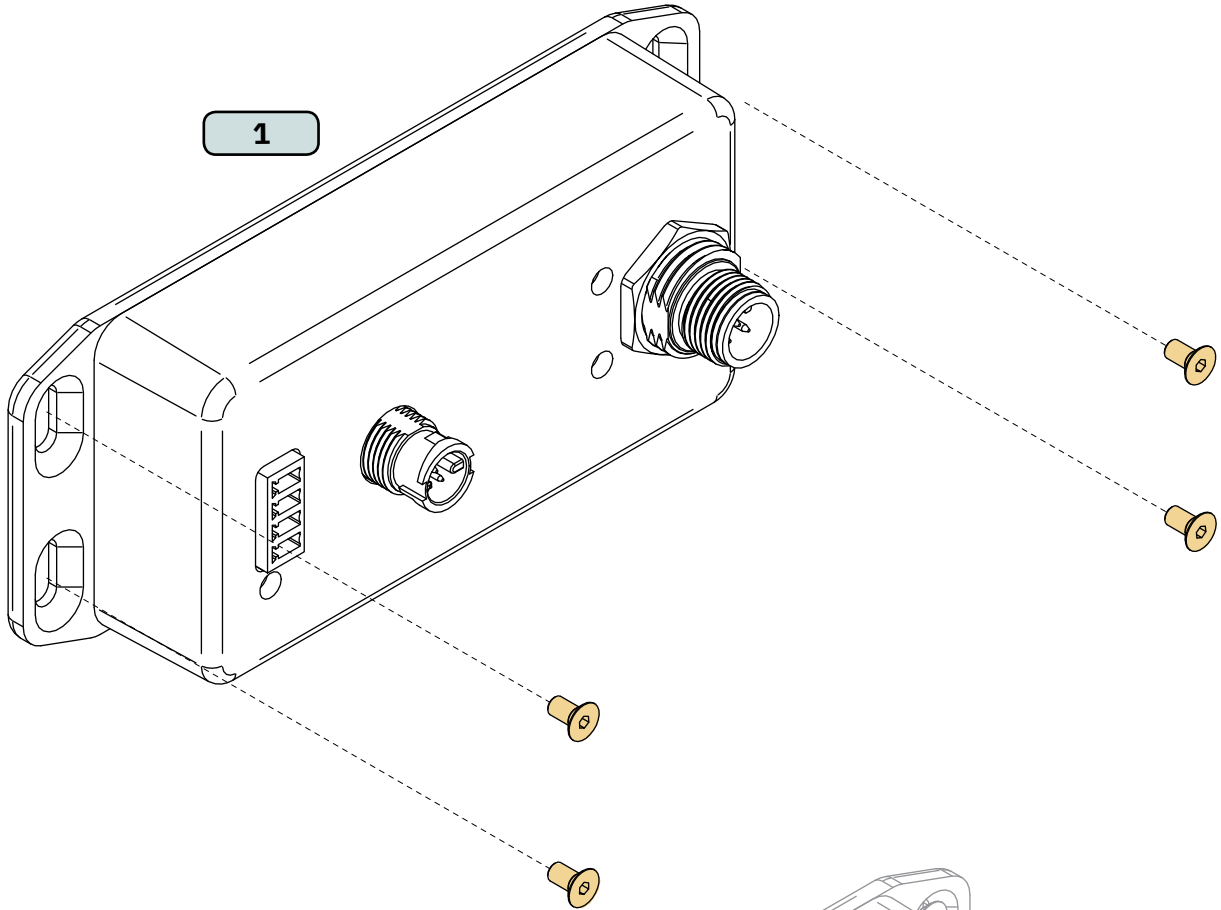

MG_0486

Measurement code	Measurement description	GW-2Y	
		mm	inch
+H	Total Gateway Height	41	1.6
H	Gateway Height	25.5	1
W	Gateway Width	50	2
L	Total Gateway Length	126.5	5
+L	Gateway Length	100	3.9

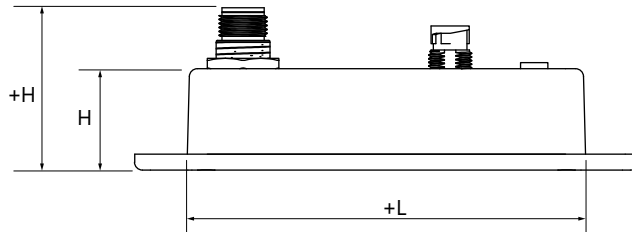
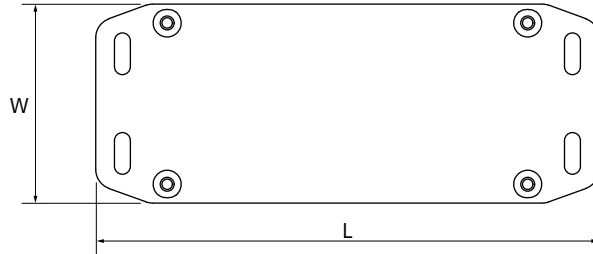

MG_0427

Technical Specifications

MC_0763

Supply Voltage	8-31VDC, Powered from S-Link
Power Consumption	1 W
CAN INTERFACE M12 male connector	CAN 2.0B, baud rate 250Kb
NMEA 0183 Connector	GPS RX @ 4800 baud or 38400 baud
NMEA 0183 Power Output	Max 100mA (internally fused)
Weight	200g/7.05oz

S-Link is a CAN-based control system used for communication between Sleipner products installed on a vessel. The system uses BACKBONE Cables as a common power and communication bus with separate SPUR Cables to each connected unit. Only one S-Link POWER cable shall be connected to the BACKBONE Cable. Units with low power consumption are powered directly from the S-Link bus.

Main advantages of S-Link system:

- Compact and waterproof plugs.
- BACKBONE and SPUR Cables have different colour coding and keying to ensure correct and easy installation. BACKBONE Cables have blue connectors and SPUR Cables have green connectors.
- Different cable lengths and BACKBONE Extenders make the system scalable and flexible to install.

Installation of S-Link cables:

Select appropriate cables to keep the length of BACKBONE- and SPUR Cables to a minimum. In case of planned installation with total BACKBONE Cable length exceeding 100 meters please consult your local distributor. The S-Link cables should be properly fastened when installed to avoid sharp bend radius, cable chafing and undesired strain on connectors. Locking mechanism on connectors must be fully closed. To ensure long lifetime, cables, T-Connectors and Extenders should not be located so that they are permanently immersed in water or other fluids. It is also recommended to install cables such that water and condensation do not run along the cables and into the connectors.

The POWER Cable should ideally be connected around the middle of the BACKBONE bus to ensure an equal voltage drop at each end of the BACKBONE Cable. The yellow and black wire in the POWER Cable shall be connected to GND and the red wire connected to +12VDC or +24VDC.

To reduce the risk of interference, avoid routing the S-Link cables close to equipment such as radio transmitters, antennas or high voltage cables. The backbone must be terminated at each end with the END Terminator.

SPUR cables can be left unterminated to prepare for the installation of future additional equipment. In such cases, ensure to protect open connectors from water and moisture to avoid corrosion in the connectors.

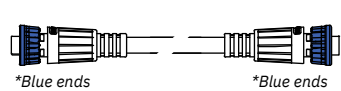

BACKBONE Cable

Forms the communication and power bus throughout a vessel. Available in different standard lengths.

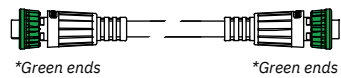

SPUR Cable

Used to connect S-Link compliant products to the backbone cable. One SPUR Cable must be used for each connected component, with no exceptions. Recommended to be as short as practically possible. Available in different standard lengths.

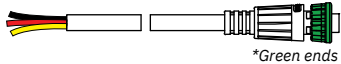

POWER Cable

Required in all installations for connection of BACKBONE Cable to a power supply and should be protected with a 2A fuse.

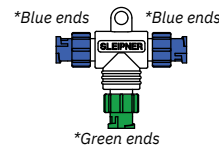

T-Connector

Used for connection of SPUR or POWER Cable to the BACKBONE Cable. One T-Connector for each connected cable.

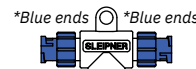

BACKBONE Extender

Connects two BACKBONE Cables to extend the length.

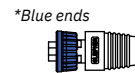

END Terminator

Must be one at each end of the BACKBONE bus.

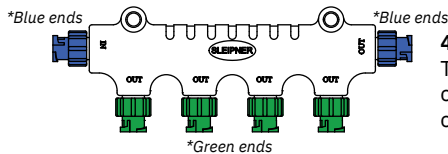

4-Port T-Connector

The 4-PORT T-connector allows multiple SPUR Cables to be connected. The 4-PORT T-connector comes with two sealing caps to protect unused ports.

S-Link installation example

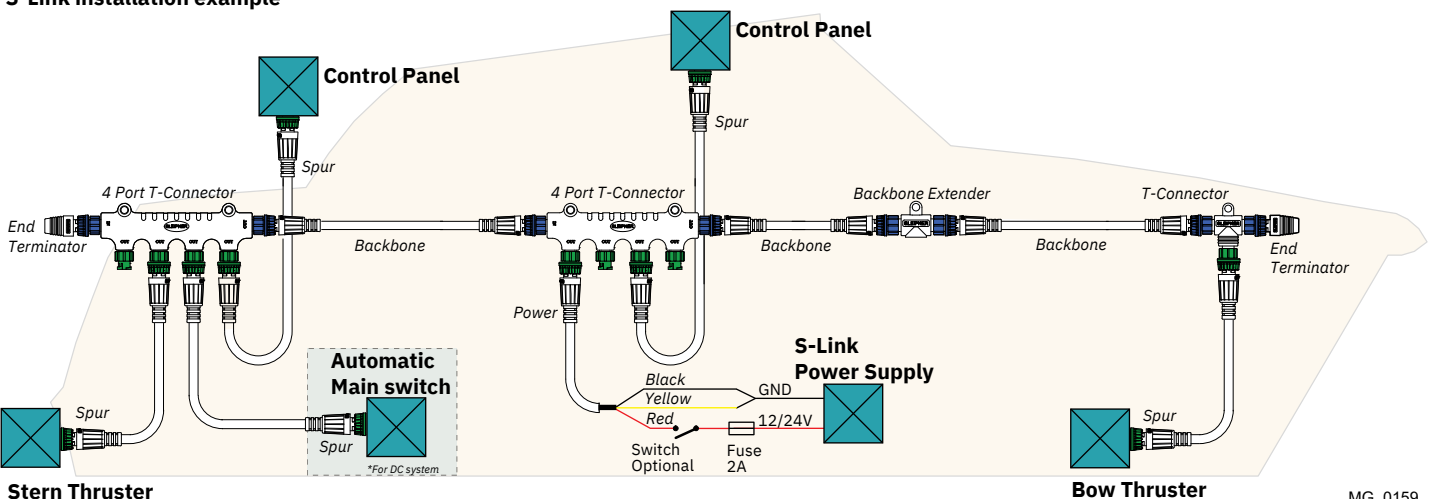

MG_0159

Typically NMEA2000® Connection Diagram

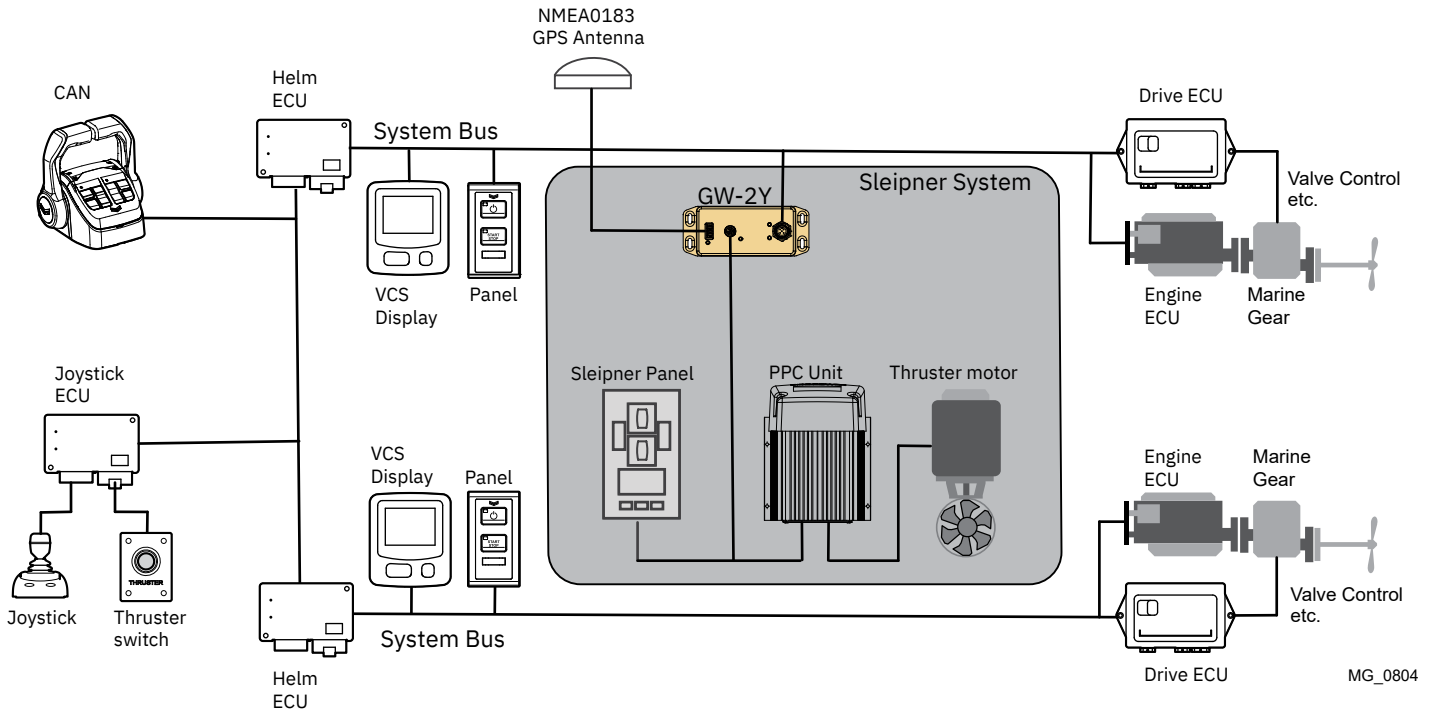

Find your local professional dealer from our certified worldwide network for expert service and support. visit our website www.sleipnergrouper.com/support

Product Spare Parts and Additional Resources

For additional supporting documentation, we advise you to visit our website www.sleipnergrouper.com and find your Sleipner product.

Warranty statement

1. Sleipner Motor AS (The “Warrantor”) warrants that the equipment (parts, materials, and embedded software of products) manufactured by the Warrantor is free from defects in workmanship and materials for purpose for which the equipment is intended and under normal use and maintenance service (the “Warranty”).
2. This Warranty is in effect for two years (Leisure Use) or one year (Commercial and other Non-leisure Use) from the date of delivery/purchase by the end user, with the following exceptions;
 - (a) For demonstration vessels, or vessels kept on the water, the dealer is considered as the end user from 6 months after their launch of the vessel;
 - (b) The warranty period starts no later than 18 months after the first launch of the vessel.
 Please note that the boat manufacturer and dealer must pay particular attention to correct maintenance and service both by the products manuals as well as general good practice for the location the boat is kept in the period the boat is in their care. In cases where the 6 and 18 months grace periods for boat builders and dealers are passed, it is possible to obtain a full warranty upon inspection and approval of the warrantor or such representative.
3. Certain parts, classified as wearable or service parts, are not covered by the warranty. A failure to follow the required maintenance and service work as described in the product manual render all warranty on parts or components directly or indirectly affected by this void. Please also note that for some parts, time is also a factor separately from actual operational hours.
4. This Warranty is transferable and covers the equipment for the specified warranty period.
5. The warranty does not apply to defects or damages caused by faulty installation or hook-up, abuse or misuse of the equipment including exposure to excessive heat, salt or fresh water spray, or water immersion except for equipment specifically designed as waterproof.
6. In case the equipment seems to be defective, the warranty holder (the “Claimant”) must do the following to make a claim:
 - (a) Contact the dealer or service centre where the equipment was purchased and make the claim. Alternatively, the Claimant can make the claim to a dealer or service centre found at www.sleipnergrouper.com. The Claimant must present a detailed written statement of the nature and circumstances of the defect, to the best of the Claimant’s knowledge, including product identification and serial nbr., the date and place of purchase and the name and address of the installer. Proof of purchase date should be included with the claim, to verify that the warranty period has not expired;
 - (b) Make the equipment available for troubleshooting and repair, with direct and workable access, including dismantling of furnishings or similar, if any, either at the premises of the Warrantor or an authorised service representative approved by the Warrantor. Equipment can only be returned to the Warrantor or an authorised service representative for repair following a pre-approval by the Warrantor’s Help Desk and if so, with the Return Authorisation Number visible postage/shipping prepaid and at the expense of the Claimant.
7. Examination and handling of the warranty claim:
 - (a) If upon the Warrantor’s or authorised service Representative’s examination, the defect is determined to result from defective material or workmanship in the warranty period, the equipment will be repaired or replaced at the Warrantor’s option without charge, and returned to the Purchaser at the Warrantor’s expense. If, on the other hand, the claim is determined to result from circumstances such as described in section 4 above or a result of wear and tear exceeding that for which the equipment is intended (e.g. commercial use of equipment intended for leisure use), the costs for the troubleshooting and repair shall be borne by the Claimant;
 - (b) No refund of the purchase price will be granted to the Claimant, unless the Warrantor is unable to remedy the defect after having a reasonable number of opportunities to do so. In the event that attempts to remedy the defect have failed, the Claimant may claim a refund of the purchase price, provided that the Claimant submits a statement in writing from a professional boating equipment supplier that the installation instructions of the Installation and Operation Manual have been complied with and that the defect remains.
8. Warranty service shall be performed only by the Warrantor, or an authorised service representative, and any attempt to remedy the defect by anyone else shall render this warranty void.
9. No other warranty is given beyond those described above, implied or otherwise, including any implied warranty of merchantability, fitness for a particular purpose other than the purpose for which the equipment is intended, and any other obligations on the part of the Warrantor or its employees and representatives.
10. There shall be no responsibility or liability whatsoever on the part of the Warrantor or its employees and representatives based on this Warranty for injury to any person or persons, or damage to property, loss of income or profit, or any other incidental, consequential or resulting damage or cost claimed to have been incurred through the use or sale of the equipment, including any possible failure or malfunction of the equipment or damages arising from collision with other vessels or objects.
11. This warranty gives you specific legal rights, and you may also have other rights which vary from country to country.

Patents

At Sleipner we continually reinvest to develop and offer the latest technology in marine advancements. To see the many unique designs we have patented visit our website www.sleipnergrouper.com/patents

© **Sleipner Group**, All rights reserved
The information given in the document
was right at the time it was published.
However, Sleipner Group cannot
accept liability for any inaccuracies or
omissions it may contain. Continuous
product improvement may change the
product specifications without notice.
Therefore, Sleipner Group cannot accept
liability for any possible differences
between product and document.

Learn more about our products at
www.sleipnergroup.com



SLEIPNER GROUP

P.O. Box 519

N-1612 Fredrikstad

Norway

www.sleipnergroup.com

Made in Norway

