

Keep this  
manual onboard!



# User Manual

*Including Installation For S-Link Gateway  
GW-2Y*



DOCUMENT ID: 7807

REVISION: 3

DATE: 2025

LANGUAGE: EN



# Contents

<b>Warnings and Safety</b> .....	<b>2</b>
Responsibility of the operator .....	2
Introduction .....	3
CAN Interface .....	3
NMEA0183 Interface.....	3
<b>Installation Guide</b>	
Responsibility of the Installer .....	4
S-Link Gateway Installation .....	5
GW-1 Gateway Measurements .....	6
Technical Specifications .....	6
S-Link System Description .....	7
Typically NMEA2000® Connection Diagram .....	8
Sleipner Group Waste Disposal and Recycling Guide .....	8
<b>Service and Support</b> .....	<b>9</b>
<b>Product Spare Parts and Additional Resources</b> .....	<b>9</b>
<b>Warranty Statement</b> .....	<b>9</b>

## Warnings and Safety

MC\_0800

It is essential to follow all instructions within this document to avoid potential personal injury, death, or damage to existing products in the vessel, the vessel's hull integrity, and including this product during installation or operation. Failure to follow instructions within this document will render all warranties given by Sleipner Motor as VOID.

Warnings and situations requiring extra caution are outlined in the documentation. Take extra consideration when warnings are outlined.



### WARNING

Indicate a potentially hazardous situation that, if not avoided, could result in death or severe injury.



### CAUTION

Indicates a potentially hazardous situation that could result in minor or moderate injury or critical damage to vessel integrity if not avoided.

## Responsibility of the Operator

MC\_0801

### General:

- The operator must read this document to ensure necessary familiarity with the product before use.
- It is the owner/ captain/ operators full responsibility to assess the risk of any unexpected incidents or situation on the vessel or at sea. Familiarise yourself with your vessels safety operation in conjunction with Sleipner products.
- DO NOT allow children to operate Sleipner products.



### WARNING

Sleipner Motor AS is not responsible for damage or injury caused by the misuse of our products.

MC\_0020

## Introduction

MC\_0761

S-Link gateway GW-2Y is a device for connecting Yanmar J1939 bus to the S-Link bus. Connect an S-Link spur cable from the gateway to the S-Link backbone, and non S-Link equipment to the CAN Interface M12 male connector or NMEA0183 GPS antenna to the NMEA0183 connector.

Power to the gateway is supplied from the S-Link so no external power is required.

## CAN Interface

MC\_0761

### Connection

The GW-2Y does not feed any power to the CAN-bus and connected devices has to be power feed from elsewhere. The GW-2Y does not include any termination resistor on the M12 male connector output, so terminating resistors is required on the CAN-bus. CAN-L & CAN-H are galvanic isolated. Sleipner Motor AS do not provide cables for the CAN Interface bus.

### LED indication

TX LED(Reference 1) off:	Not sending any messages.
TX LED flashing:	Flashing at max 100ms on and 100ms off when sending messages.
RX LED (Reference 2) off:	Not receiving any messages.
RX LED flashing:	Flashing at max 100ms on and 100ms off when receiving messages

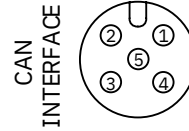

M12 Input Male Connector  
(View into connector)  
Pin 1 NC  
Pin 2 NC  
Pin 3 GND  
Pin 4 CAN-H  
Pin 5 CAN-L

MG\_0802

## NMEA0183 Interface

MC\_0765

### Connection

The V OUT pin can feed power to a single GPS antenna with maximum 100mA, and it is internally fused. V OUT is S-link bus voltage. RX A(+) & TX B(-) are galvanic isolated

### Baud rate

4800 baud and 38400 baud is supported, and are set automatically.

### Supported NMEA0183 sentences

\$GxRMC sentences from all positioning systems is supported.

### LED indication (Reference 3)

LED off:	No valid NMEA0183 GPS signals.
LED flashing:	Flashing 100ms on and 100 off for each valid GPS message received. - Valid GPS antenna message at 38400 baud normal flashing on/off (100ms/100ms). - Valid GPS antenna message at 4800 baud normal flashing on/off (100ms/900ms)

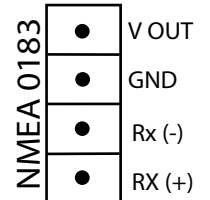

### GNSS Antenna Prioritization

GNSS antennas priority sequence is 1. NMEA0183 with 100ms update rate 2. NMEA0183 with 1000ms update rate.

GW-2Y will only forward one of the NMEA2000® GPS antenna signal to S-link if more than one antennas is present on the NMEA2000® bus.

If more than one GW-2Y have GNSS signal(s) then GW-2Y's will prioritize on antenna type from the list above and only one GW-2Y will broadcast GNSS signals on the S-link bus.

All this requires GW-2Y firmware V1.021 or newer.

### Status LED (Reference 4)

LED off:	No power to the device.
LED on:	S-Link communication and power OK.
LED flashing (on/off (500ms/500ms)):	No S-Link communication but power is OK.

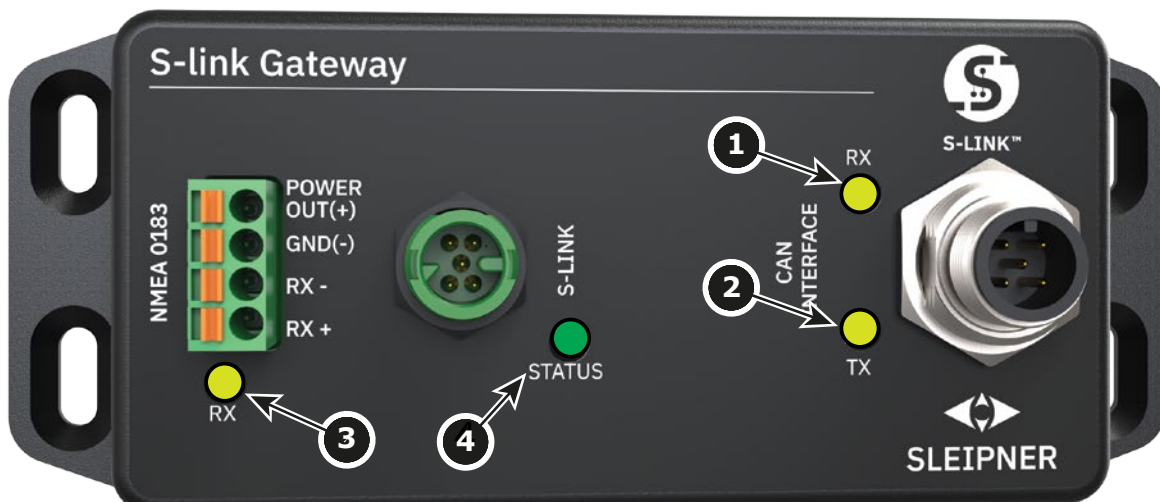

## Responsibility of the installer

MC\_0038

### General:

- The installer must read this document to ensure necessary familiarity with the product before installation.
- Directions outlined in this document cannot be guaranteed to comply with all international and national regulations, including but not limited to health and safety procedures. It is the installers responsibility to adhere to all applicable international and national regulations when installing Sleipner products.
- This document contains general installation guidelines intended to support experienced installers. Contact professional installers familiar with the vessel, Sleipner products and applicable regulations if assistance is required.
- If local regulation requires any electrical work to be performed by a licensed professional, seek a licensed professional.
- When planning the installation of Sleipner products, ensure easy access to the products for future service and inspection requirements.

### For Sleipner S-Link™ systems:

- When installing an S-Link™ system, connect ONLY original Sleipner S-Link™ products or other authorized control equipment directly to the S-Link™ bus. When connecting non-authorized third-party equipment, it must always be connected through a Sleipner-supplied interface product. MC\_0105
- Any attempt to directly control or connect to the S-Link™ control system without a designated and approved interface from Sleipner will void all warranties and responsibilities of the connected Sleipner products. If you interface the S-Link™ bus by agreement with Sleipner through a designated Sleipner-supplied interface, you are still required to install at least one original Sleipner control panel to enable efficient troubleshooting if necessary.



### WARNING

Failure to follow any considerations and precautions can lead to serious personal injury, death and/or damage your product.  
Failure to follow any considerations and precautions will render all warranties given by Sleipner Motor as VOID.

MC\_0411

1. Fasten the GW-2Y box to a solid surface using four mounting screws.
2. Attach the required cables to the GW-2Y.

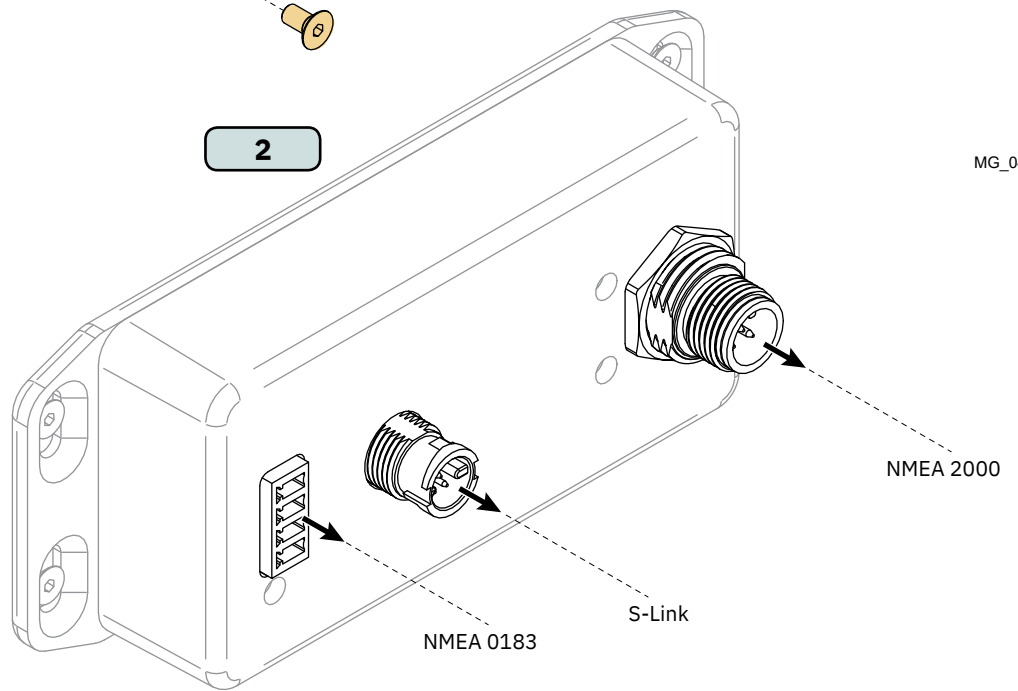
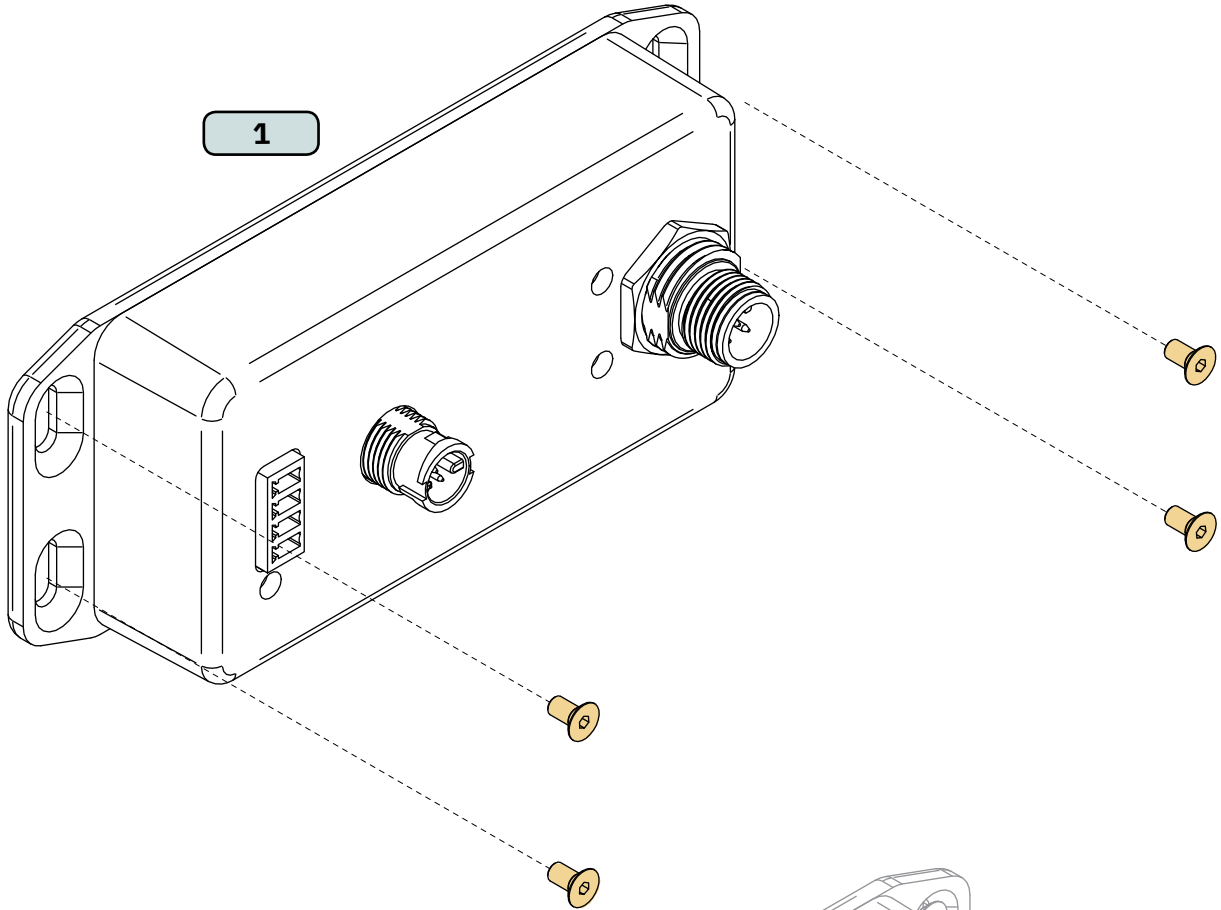

MG\_0486

Measurement code	Measurement description	GW-2Y	
		mm	inch
+H	Total Gateway Height	41	1.6
H	Gateway Height	25.5	1
W	Gateway Width	50	2
L	Total Gateway Length	126.5	5
+L	Gateway Length	100	3.9

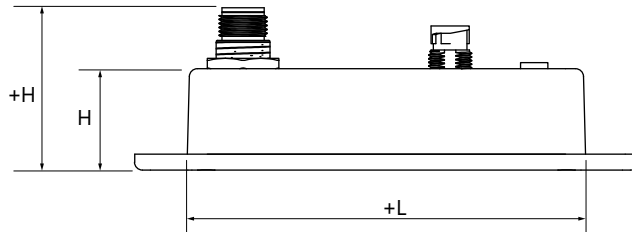
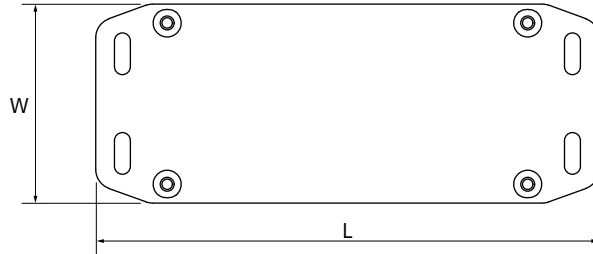

MG\_0427

## Technical Specifications

MC\_0763

Supply Voltage	8-31VDC, Powered from S-Link
Power Consumption	1 W
CAN INTERFACE M12 male connector	CAN 2.0B, baud rate 250Kb
NMEA 0183 Connector	GPS RX @ 4800 baud or 38400 baud
NMEA 0183 Power Output	Max 100mA (internally fused)
Weight	200g/7.05oz

S-Link is a CAN-based control system used for communication between Sleipner products installed on a vessel. The system uses BACKBONE Cables as a common power and communication bus with separate SPUR Cables to each connected unit. Only one S-Link POWER cable shall be connected to the BACKBONE Cable. Units with low power consumption are powered directly from the S-Link bus.

**Main advantages of S-Link system:**

- Compact and waterproof plugs.
- BACKBONE and SPUR Cables have different colour coding and keying to ensure correct and easy installation. BACKBONE Cables have blue connectors and SPUR Cables have green connectors.
- Different cable lengths and BACKBONE Extenders make the system scalable and flexible to install.

**Installation of S-Link cables:**

Select appropriate cables to keep the length of BACKBONE- and SPUR Cables to a minimum. In case of planned installation with total BACKBONE Cable length exceeding 100 meters please consult your local distributor. The S-Link cables should be properly fastened when installed to avoid sharp bend radius, cable chafing and undesired strain on connectors. Locking mechanism on connectors must be fully closed. To ensure long lifetime, cables, T-Connectors and Extenders should not be located so that they are permanently immersed in water or other fluids. It is recommended to install cables in such a way that water and condensation do not flow along the cables into the connectors. This can be done for example by introducing a u-shape bend before the cable enters the product connector.

Ideally, the POWER Cable should be connected to the middle of the BACKBONE bus to ensure an equal voltage drop at both ends of the BACKBONE Cable. The yellow and black wire in the POWER Cable shall be connected to GND and the red wire connected to +12VDC or +24VDC.

To reduce the risk of interference, avoid routing the S-Link cables close to equipment such as radio transmitters, antennas or high voltage cables. The backbone must be terminated at each end with the END Terminator.

SPUR cables can be left unterminated to prepare for the installation of future additional equipment. In such cases, ensure to protect open connectors from water and moisture to avoid corrosion in the connectors.

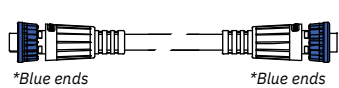

**BACKBONE Cable**

Forms the communication and power bus throughout a vessel. Available in different standard lengths.

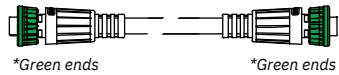

**SPUR Cable**

Used to connect S-Link compliant products to the backbone cable. One SPUR Cable must be used for each connected component, with no exceptions. Recommended to be as short as practically possible. Available in different standard lengths.

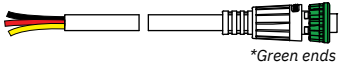

**POWER Cable**

Required in all installations for connection of BACKBONE Cable to a power supply and should be protected with a 2A fuse.

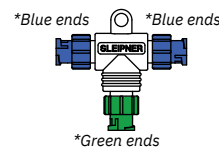

**T-Connector**

Used for connection of SPUR or POWER Cable to the BACKBONE Cable. One T-Connector for each connected cable.



**BACKBONE Extender**

Connects two BACKBONE Cables to extend the length.

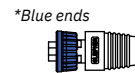

**END Terminator**

Must be one at each end of the BACKBONE bus.

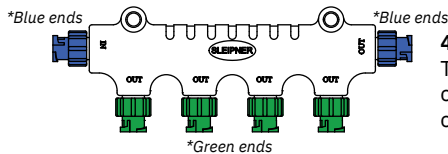

**4-Port T-Connector**

The 4-PORT T-connector allows multiple SPUR Cables to be connected. The 4-PORT T-connector comes with two sealing caps to protect unused ports.

**S-Link installation example**

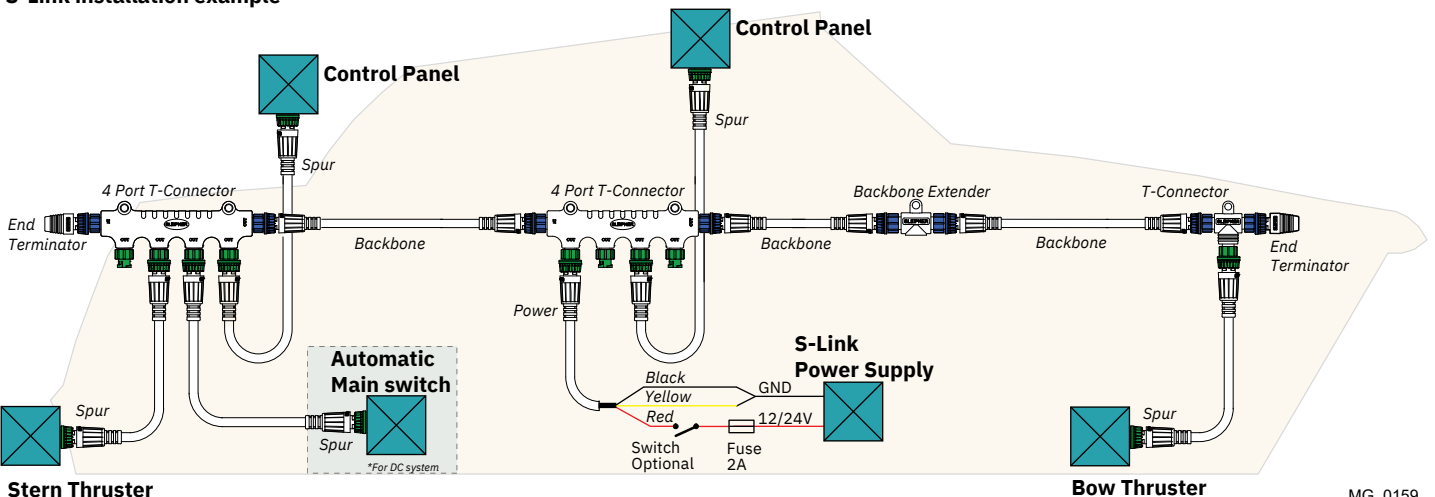

MG\_0159

## Typically NMEA2000® Connection Diagram

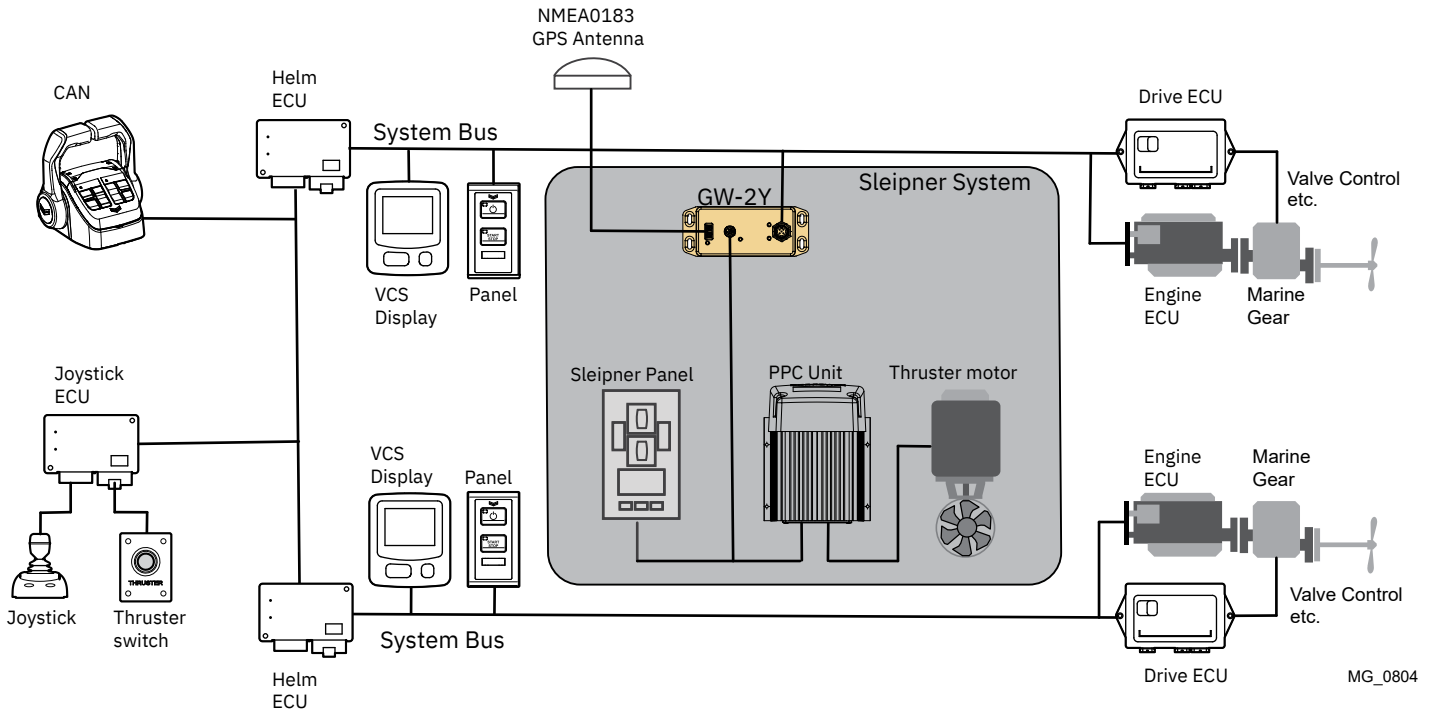

MG\_0804

## Sleipner Group Waste Disposal and Recycling Guide

MC\_0848

### Introduction:

At Sleipner Group, we prioritize sustainability and encourage the repair and re-manufacturing of products to extend their life cycles. If disposal is necessary, please follow these guidelines to recycle and manage waste responsibly, ensuring our efforts align with environmental protection efforts.

### Electric Motors and Electronics:

- Disconnect from any power sources and dismantle them carefully.
- Recycle components through certified e-waste recycling centers that can adequately handle and recover electronic materials.
- Dispose of any non-recyclable electronic parts according to local environmental regulations.

### Metals:

- Collect and sort metal parts for recycling as scrap metal.
- To increase recycling efficiency, ensure that metals are clean and free from non-metal attachments.

### Plastics:

- Identify recyclable plastics based on local recycling guidelines.
- Remove any non-plastic components and clean them before recycling to improve the quality of the recycled material.

### Hazardous Materials:

- Correctly identify any hazardous substances within components, such as batteries or capacitors etc.
- Follow local regulations for the safe disposal of hazardous materials to prevent pollution and protect environmental health.

### General Disposal Instructions:

- Consult local recycling programs to determine the acceptability of various materials.
- Use authorized disposal services to ensure compliance with environmental standards.

### Safe Disposal Practices:

- Adhere to local laws and regulations for waste management to minimize environmental impact and ensure community safety.

This guide is designed to help reduce our products' environmental footprint through responsible end-of-life management. Please contact your local waste management supplier or our support team for more specific disposal information or further assistance.



**Find your local professional dealer from our certified worldwide network for expert service and support. visit our website [www.sleipnergrou.com/support](http://www.sleipnergrou.com/support)**

## Product spare parts and additional resources

**For additional supporting documentation, we advise you to visit our website [www.sleipnergrou.com](http://www.sleipnergrou.com) and find your Sleipner product.**

## Warranty statement

1. Sleipner Motor AS (The “Warrantor”) warrants that the equipment (parts, materials, and embedded software of products) manufactured by the Warrantor is free from defects in workmanship and materials for purpose for which the equipment is intended and under normal use and maintenance service (the “Warranty”).
2. This Warranty is in effect for two years (Leisure Use) or one year (Commercial and other Non-leisure Use) from the date of delivery/purchase by the end user, with the following exceptions:
  - (a) For demonstration vessels, or vessels kept on the water, the dealer is considered as the end user from 6 months after their launch of the vessel;
  - (b) The warranty period starts no later than 18 months after the first launch of the vessel.
 Please note that the boat manufacturer and dealer must pay particular attention to correct maintenance and service both by the products manuals as well as general good practice for the location the boat is kept in the period the boat is in their care. In cases where the 6 and 18 months grace periods for boat builders and dealers are passed, it is possible to obtain a full warranty upon inspection and approval of the warrantor or such representative.
3. Certain parts, classified as wearable or service parts, are not covered by the warranty. A failure to follow the required maintenance and service work as described in the product manual render all warranty on parts or components directly or indirectly affected by this void. Please also note that for some parts, time is also a factor separately from actual operational hours.
4. This Warranty is transferable and covers the equipment for the specified warranty period.
5. The warranty does not apply to defects or damages caused by faulty installation or hook-up, abuse or misuse of the equipment including exposure to excessive heat, salt or fresh water spray, or water immersion except for equipment specifically designed as waterproof.
6. In case the equipment seems to be defective, the warranty holder (the “Claimant”) must do the following to make a claim:
  - (a) Contact the dealer or service centre where the equipment was purchased and make the claim. Alternatively, the Claimant can make the claim to a dealer or service centre found at [www.sleipnergrou.com](http://www.sleipnergrou.com). The Claimant must present a detailed written statement of the nature and circumstances of the defect, to the best of the Claimant’s knowledge, including product identification and serial nbr., the date and place of purchase and the name and address of the installer. Proof of purchase date should be included with the claim, to verify that the warranty period has not expired;
  - (b) Make the equipment available for troubleshooting and repair, with direct and workable access, including dismantling of furnishings or similar, if any, either at the premises of the Warrantor or an authorised service representative approved by the Warrantor. Equipment can only be returned to the Warrantor or an authorised service representative for repair following a pre-approval by the Warrantor’s Help Desk and if so, with the Return Authorisation Number visible postage/shipping prepaid and at the expense of the Claimant.
7. Examination and handling of the warranty claim:
  - (a) If upon the Warrantor’s or authorised service Representative’s examination, the defect is determined to result from defective material or workmanship in the warranty period, the equipment will be repaired or replaced at the Warrantor’s option without charge, and returned to the Purchaser at the Warrantor’s expense. If, on the other hand, the claim is determined to result from circumstances such as described in section 4 above or a result of wear and tear exceeding that for which the equipment is intended (e.g. commercial use of equipment intended for leisure use), the costs for the troubleshooting and repair shall be borne by the Claimant;
  - (b) No refund of the purchase price will be granted to the Claimant, unless the Warrantor is unable to remedy the defect after having a reasonable number of opportunities to do so. In the event that attempts to remedy the defect have failed, the Claimant may claim a refund of the purchase price, provided that the Claimant submits a statement in writing from a professional boating equipment supplier that the installation instructions of the Installation and Operation Manual have been complied with and that the defect remains.
8. Warranty service shall be performed only by the Warrantor, or an authorised service representative, and any attempt to remedy the defect by anyone else shall render this warranty void.
9. No other warranty is given beyond those described above, implied or otherwise, including any implied warranty of merchantability, fitness for a particular purpose other than the purpose for which the equipment is intended, and any other obligations on the part of the Warrantor or its employees and representatives.
10. There shall be no responsibility or liability whatsoever on the part of the Warrantor or its employees and representatives based on this Warranty for injury to any person or persons, or damage to property, loss of income or profit, or any other incidental, consequential or resulting damage or cost claimed to have been incurred through the use or sale of the equipment, including any possible failure or malfunction of the equipment or damages arising from collision with other vessels or objects.
11. This warranty gives you specific legal rights, and you may also have other rights which vary from country to country.

## Patents

At Sleipner we continually reinvest to develop and offer the latest technology in marine advancements. To see the many unique designs we have patented, visit our website [www.sleipnergrou.com/patents](http://www.sleipnergrou.com/patents)

© **Sleipner Motor AS**, All rights reserved

The information given in the document was right at the time it was published. However, Sleipner Motor AS cannot accept liability for any inaccuracies or omissions it may contain. Continuous product improvement may change the product specifications without notice. Therefore, Sleipner Motor AS cannot accept liability for any possible differences between product and document.

**Learn more about our products at**  
**[www.sleipnergroun.com](http://www.sleipnergroun.com)**



**SLEIPNER MOTOR AS**

P.O. Box 519

N-1612 Fredrikstad

Norway

[www.sleipnergroun.com](http://www.sleipnergroun.com)

Made in Norway